

ELECTROFUSION 45 AND 90 ELBOWS



PE4710 / PE100

1" IPS" - 4" IPS

40 Volts, 4.0MM Pin with Universal Barcode

*Fusion and Cooling times are clearly marked on the barcode of every fitting.
This information may also be obtained with the barcode reader.*

Plasson USA Electrofusion Fittings are specifically designed for reliable, high performance pipe joining and long system life. The Plasson automated Electrofusion system has been proven to be the most economical due to the low potential for operator error.

Plasson USA Electrofusion Elbows have long penetration depths and fusion zones which ensure high quality joints. They are designed, tested and quality controlled in accordance with Plasson's internal standards. Plasson USA Electrofusion Fittings meet or exceed the following standards:

- ASTM D2513
- ISO 8085
- AWWA C906
- ASTM F1055
- ISO 14236
- FM 1613 (FM Approved Fittings Only)
- ASTM F2897



INDUSTRIAL



GAS



MINING



WATER



FIRE
PROTECTION



LANDFILL

PRODUCT DATA

PRODUCT CODE	PRODUCT DESCRIPTION	PRIMARY DIMENSION	SECONDARY DIMENSION	PRESSURE RATING GAS	PRESSURE CLASS (WATER)	FITTING RAW MATERIAL	AMBIENT FUSION TEMPERATURE
5906B	Elbow 45°	1-2 IPS	N/A	125 PSI	160 PSI	PE 4710/PE 100	14 - 113°F

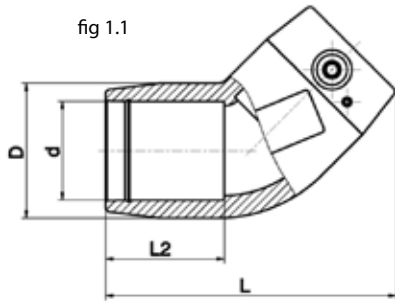

FIG 1.1										
ITEM NUMBER	PIPE SIZE	d inch (mm)	D inch (mm)	L inch (mm)	L1 inch (mm)	Ω @ 20°C ohms	FUSE TIME (sec.)	COOL TIME (min.)	WEIGHT lb (g)	
5906B003010	1 IPS	1.36 (33.9)	1.75 (44)	3.74 (102)	1.54 (39)	2.0000	30	5	0.18 (71)	
5906B003013	1 1/4 IPS	1.72 (42.9)	2.19 (56)	4.25 (108)	1.71 (44)	2.060	60	5	0.31 (108)	
5906B003015	1 1/2 IPS	1.95 (48.8)	2.67 (68)	4.88 (124)	1.91 (49)	2.500	120	10	0.49 (193)	
5906B003020	2 IPS	2.44 (60.9)	3.23 (82)	5.87 (149)	2.26 (58)	1.310	80	5	0.73 (292)	

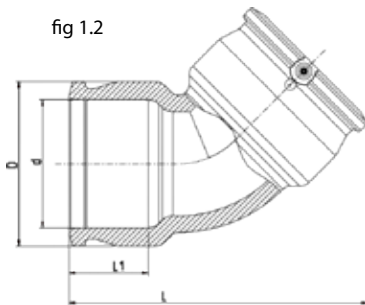

FIG 1.2										
ITEM NUMBER	PIPE SIZE	d inch (mm)	D inch (mm)	L inch (mm)	L1 inch (mm)	Ω @ 20°C ohms	FUSE TIME (sec.)	COOL TIME (min.)	WEIGHT lb (g)	
5906B003030	3 IPS	3.58 (89.4)	4.42 (113)	9.00 (225)	2.8 (71)	0.723	100	10	1.67 (745)	
5906B003040	4 IPS	4.59 (114.7)	5.61 (143)	10.70 (257)	3.19 (68)	0.594	140	10	2.8 (1220)	