



Figure # 937

Ductile Iron Wafer Style Butterfly Valve

Product Features

- 200 PSI Sizes 2"-12"
- 150 PSI Sizes 14" - UP
- Ductile Iron Body
- Wafer Style Body
- Cartridge Seat
- ISO 5211 Mounting Flange
- MSS-SP-67



Figure Number Breakdown (Example 937DNSL)

Disc Matl.	Seat Matl.	Stem Matl.	Topworks
B = Aluminum Bronze	E = EPDM	M = 316 SS.	L = Lever
D = Ductile Iron w/ Nickel plating	N = NBR	S = 416 SS	G = Gear
M = 316 Stainless Steel	-----	-----	X = Bare Stem

Materials & Specifications

Item	Description	Material
1	Body	Ductile Iron
2	Disc	Alum. Bronze, Ductile Iron or 316 SS.
3	Seat	ϒBU or EPDM
4	Stem	416 or 316 Stainless Steel
5	Bushings	PTFE
6	O-Ring	NBR
7	Taper Pin	Stainless Steel
8	Seat Support	Plastic

Note: Ductile Iron Disc are electroless Nickel plated

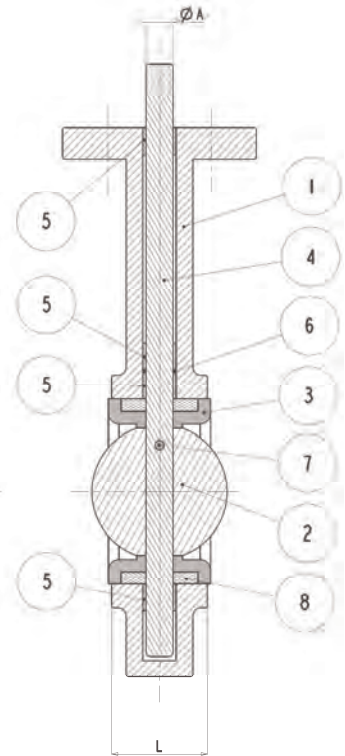

Dimensions, Weights (inches-lbs.) & Valve Data

Size	2"	2-1/2"	3"	4"	5"	6"	8"	10"	12"	14"	16"	18"	20"	24"
HA	2.99	3.5	3.74	4.49	5.0	5.51	6.81	7.99	9.57	10.51	11.73	12.52	13.74	16.14
HB	6.38	6.89	7.13	7.87	8.39	8.86	10.24	11.5	13.27	14.49	15.75	16.61	18.86	22.13
HC	1.26	1.26	1.26	1.26	1.26	1.26	1.77	1.77	1.77	1.77	2.01	2.01	2.52	2.8
L	1.69	1.81	1.81	2.05	2.2	2.2	2.36	2.68	3.07	3.07	4.02	4.49	5.0	6.0
ØK	4.75	5.5	6.0	7.5	8.5	9.5	11.75	14.25	17.0	18.75	21.25	22.75	25.0	29.5
ØF	.75	.75	.75	.75	.88	.88	.88	1.0	1.0	1.12	1.12	1.25	1.25	1.38
ØA	.5	.5	.5	.63	.75	.75	.87	1.13	1.25	1.25	1.31	1.5	1.62	1.99
N	4	4	4	4	4	4	4	4	4	4	4	4	4	4
Wt. lever	8	9	12	15	20	22	36	46	74	-	-	-	-	-
Wt. Gear	24	25	28	31	36	38	55	65	93	118	177	225	373	538

Seating torques (inch/lbs.)

PSI	2"	2-1/2"	3"	4"	5"	6"	8"	10"	12"	14"	16"	18"	20"	24"
50	100	150	207	290	423	599	1060	1671	2568	2640	4260	6287	8360	15427
100	106	163	220	323	481	691	1183	1872	2795	3070	4880	7243	9180	16813
150	111	176	232	357	540	783	1307	2074	3023	3500	5500	8200	10000	18200
200	117	189	244	390	598	875	1430	2275	3250	-	-	-	-	-

All torque values shown are for wet (water and other non-lubricating media) on-off service. For dry services (dry gas, etc.) multiply values by 1.15. For lubed service (clean, non-abrasive lubricating media) multiply values by .85. These values do not include a safety factor. An appropriate safety factor should be used when sizing any actuator.

