

# GAS DISTRIBUTION PRODUCTS

# PROPANE & PLUMBING

# CATALOG



***Continental Industries***

A Division of  **BURNDY** LLC

The Ultimate Connection  
[www.conind.com](http://www.conind.com)

# ABOUT US



*For more than 50 years, Continental Industries has been and industry leader in the manufacture of connector fittings for the safe and reliable delivery of natural gas, propane and water.*

Headquartered in Tulsa, Oklahoma – with manufacturing facilities in both Tulsa and Broken Arrow. We engineer and assemble, with a commitment to providing our customers the highest quality products at the best value.

For gas distribution, Continental supplies a full line of specialty products, offering turnkey solutions for main-to-meter connections. No other single manufacturer can offer the variety of fittings that Continental Industries provides. Whether you need to connect PE to PE, PE to PVC, PE to Steel, PE to Copper or Steel to Steel, chances are Continental has one to do the job. Continental is an ISO 9001 certified company. Our products meet or exceed all ASTM and D.O.T. requirements and make safe, reliable and economical connections.

To our long-standing customers, we thank you for your loyalty and honoring us with your business. If you are new with Continental Industries, we will work tirelessly to exceed your expectations through our expertise, versatility and customer service. Whether you require our Con-Stab ID Seal® fittings, the Eliminator® mechanical saddles, Steel Punch Tees or any of the myriad of products we offer, we encourage you to join the ranks of long-standing satisfied customer relationships we've forged throughout the years.

## TABLE OF CONTENTS

Con-Stab ID Seal® Fittings .....	3-8	Anodeless Meter Risers .....	26-27
The Scope® Expandable Joint Repair Couplings.....	9-11	Conflex Risers.....	28-29
Con-Stab ID Seal® Eliminator Saddles.....	12-15	Riser Brackets.....	30
Con-Stab ID Seal® PE Valve Tee .....	16-17	Chamfer Tools & Eliminator Saddle Accessories.....	31
Transition Fittings.....	18-19	Protective Sleeves .....	32
PA Compression Fittings .....	20-21	Assembly Instructions .....	33
PA Eliminator Saddles .....	22-25		



# CON-STAB ID SEAL® FITTINGS

## CON-STAB ID SEAL® FITTINGS

Con-Stab ID Seal® fittings have been sold to the Gas Distribution, Plumbing and Propane markets since 1990. Millions are in service throughout the U.S. Continental's unique ID Seal design enables the seal to be maintained on the smooth inside surface of the polyethylene pipe, regardless of the exterior surface of the piping. This improved seal protection creates the ultimate design for mechanical joints.

The Con-Stab ID Seal® fittings provide the user with the following advantages:

- Cost effective joining method
- Simple assembly
- No additional assembly equipment required for installation (just chamfer pipe and push)
- Expanded product line with various configurations and material options (PE 3408/4710 or PE 2406)
- Uni-body design eliminating all external parts
- Pressure rating that meets or exceeds the maximum design pressure of the piping system
- Meets or exceeds all D.O.T., ASTM and NFPA 58 requirements

Each Con-Stab ID Seal® fitting provides the following unique features:

- Two internal seals
- Fixed stiffener
- Self-locking gripper
- Moisture lip

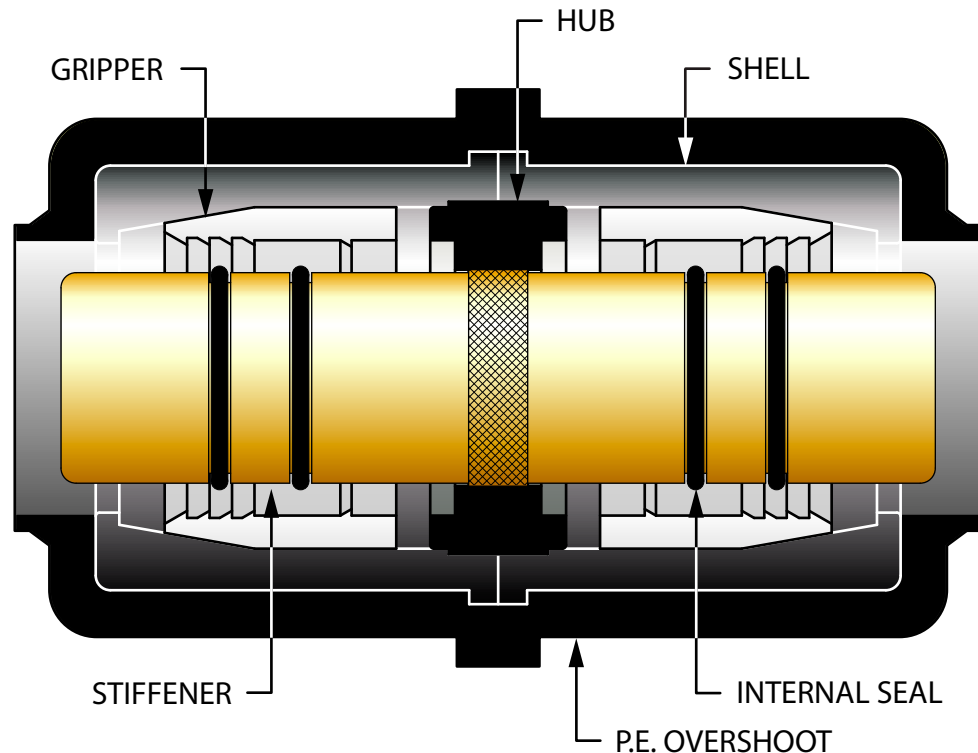

Continental Industries is an ISO 9001 Certified Company. Continental's Con-Stab ID Seal® product line is manufactured and tested to the following industry standards.

- ASTM D 2513 "Standard Specification for Thermoplastic Gas Pressure Pipe, Tubing and Fittings"
- ASME B31.8-1995 "Gas Transmission and Distribution Piping Systems"
- D.O.T., Title 49 of the Code of Federal Regulations, Part 192.283 (b)
- NFPA 58, LP-Gas Code
- NFPA 54, National Fuel Gas Code
- CSA
- ICC – International Plumbing Code
- IAPMO – Uniform Plumbing Code

# CON-STAB ID SEAL® FITTINGS



## CON-STAB ID SEAL® Full Couplings

PE SIZE	WALL	PART NUMBER (3408/4710)
1/2" CTS (5/8" OD)	.090	3259-52-1004-00†‡
3/4" CTS (7/8" OD)	.077	9959-52-0141-00
	.090	3259-52-1006-00‡
1" CTS (1 1/8" OD)	.099/.101	3259-52-1008-00†‡
	.090	3259-52-1008-AA‡
1 1/4" CTS (1 3/8" OD)	.090	3259-52-1039-AA
1/2" IPS	SDR-9.33 (.090)	3259-52-1012-00‡
3/4" IPS	SDR-11 (.095)	3259-52-1013-00†‡
1" IPS	SDR-11 (.119)	3259-52-1014-00†‡
1 1/4" IPS	SDR-10 (.166)	3259-52-1015-00†‡
	SDR-11 (.151)	3259-52-1015-AA
1 1/2" IPS	SDR-11 (.173)	3259-52-1016-00†‡
2" IPS	SDR-11 (.216)	3259-52-1017-00†‡



- For sizes not listed, contact Continental Industries.
- Con-Stab ID Seal® fittings rated at 125 psig.
- Recommended accessories;
  - Continental's Bladed Chamfering Tool. See page 31 for size combinations available.
- For Con-Stab ID Seal® Couplings with EFV's, contact Continental Industries.
- † = CSA Approved / ‡ = IAPMO/UPC Listed

## CON-STAB ID SEAL® End Caps

PE SIZE	WALL	PART NUMBER (3408/4710)
1/2" CTS (5/8" OD)	.090	3259-53-1004-00†‡
3/4" CTS (7/8" OD)	.077	9959-53-0015-00
	.090	3259-53-1006-00‡
1" CTS (1 1/8" OD)	.099/.101	3259-53-1008-00†‡
	.090	3259-53-1008-0A‡
1 1/4" CTS (1 3/8" OD)	.090	3259-53-1039-0A
1/2" IPS	SDR-9.33 (.090)	3259-53-1012-00‡
3/4" IPS	SDR-11 (.095)	3259-53-1013-00†‡
1" IPS	SDR-11 (.119)	3259-53-1014-00†‡
1 1/4" IPS	SDR-10 (.166)	3259-53-1015-00†‡
	SDR-11 (.151)	3259-53-1015-0A
1 1/2" IPS	SDR-11 (.173)	3259-53-1016-00†‡
2" IPS	SDR-11 (.216)	3259-53-1017-00†‡



- For sizes not listed, contact Continental Industries.
- Con-Stab ID Seal® fittings rated at 125 psig.
- Recommended accessories;
  - Continental's Bladed Chamfering Tool. See page 31 for size combinations available.
- † = CSA Approved / ‡ = IAPMO/UPC Listed

## CON-STAB ID SEAL® Cap-N-Go Couplings

PE SIZE	WALL	PART NUMBER (3408/4710)
1/2" CTS (5/8" OD)	.090	3259-57-1004-00‡
1" CTS (1 1/8" OD)	.099/.101	3259-57-1008-00‡
	.090	3259-57-1008-AA
1/2" IPS	SDR-9.33 (.090)	3259-57-1012-00‡
3/4" IPS	SDR-11 (.095)	3259-57-1013-00‡
1" IPS	SDR-11 (.119)	3259-57-1014-00‡
1 1/4" IPS	SDR-10 (.166)	3259-57-1015-00‡
	SDR-11 (.151)	3259-57-1015-AA
2" IPS	SDR-11 (.216)	3259-57-1017-00‡



- For sizes not listed, contact Continental Industries.
- Con-Stab ID Seal® fittings rated at 125 psig.
- Recommended accessories;
  - Continental's Bladed Chamfering Tool. See page 31 for size combinations available.
- ‡ = IAPMO/UPC Listed



# CON-STAB ID SEAL® FITTINGS

## CON-STAB ID SEAL® 3-Way Tees

PE SIZE	WALL	PART NUMBER (3408/4710)
1/2" CTS (5/8" OD)	.090	3259-50-1004-00†‡
3/4" CTS (7/8" OD)	.090	3259-50-1006-00‡
1" CTS (1 1/8" OD)	.099/.101	3259-50-1008-00†‡
	.090	3259-50-1008-AA‡
1 1/4" CTS (1 3/8" OD)	.090	3259-50-1039-AA
1/2" IPS	SDR-9.33 (.090)	3259-50-1012-00‡
3/4" IPS	SDR-11 (.095)	3259-50-1013-00†‡
1" IPS	SDR-11 (.119)	3259-50-1014-00†‡
1 1/4" IPS	SDR-10 (.166)	3369-50-1015-00*†
	SDR-11 (.151)	3259-50-1015-AA
1 1/2" IPS	SDR-11 (.173)	3259-50-1016-00‡
2" IPS	SDR-11 (.216)	3259-50-1017-00†‡



- **For sizes not listed, contact Continental Industries.**
- Con-Stab ID Seal® fittings rated at 125 psig.
- Recommended accessories;
  - Continental's Bladed Chamfering Tool. See page 31 for size combinations available.
- † = CSA Approved / ‡ = IAPMO/UPC Listed
- \* = 1 1/4" IPS SDR-10 Fitting is only available in PE 2406 yellow.

## CON-STAB ID SEAL® 90° Elbows

PE SIZE	WALL	PART NUMBER (3408/4710)
1/2" CTS (5/8" OD)	.090	3259-51-1004-00†‡
3/4" CTS (7/8" OD)	.077	9959-51-0016-00
	.090	3259-51-1006-00‡
1" CTS (1 1/8" OD)	.099/.101	3259-51-1008-00‡
	.090	3259-51-1008-AA
1 1/4" CTS (1 3/8" OD)	.090	3259-51-1039-AA
1/2" IPS	SDR-9.33 (.090)	3259-51-1012-00‡
3/4" IPS	SDR-11 (.095)	3259-51-1013-00†‡
1" IPS	SDR-11 (.119)	3259-51-1014-00†‡
1 1/4" IPS	SDR-10 (.166)	3369-51-1015-00*†
	SDR-11 (.151)	3259-51-1015-AA
1 1/2" IPS	SDR-11 (.173)	3259-51-1016-00‡
2" IPS	SDR-11 (.216)	3259-51-1017-00†‡



- **For sizes not listed, contact Continental Industries.**
- Con-Stab ID Seal® fittings rated at 125 psig.
- Recommended accessories;
  - Continental's Bladed Chamfering Tool. See page 31 for size combinations available.
- † = CSA Approved / ‡ = IAPMO/UPC Listed
- \* = 1 1/4" IPS SDR-10 Fitting is only available in PE 2406 yellow.

## CON-STAB ID SEAL® P.E. x Copper Transition Couplings

PE SIZE	WALL	COPPER SIZE	PART NUMBER (3408/4710)
1/2" CTS (5/8" OD)	.090	1/4" OD	9943-99-0062-00‡
		3/8" OD	9943-99-0063-00‡
		1/2" OD	9943-99-0064-00‡
		5/8" OD	9943-99-0065-00‡
3/4" IPS	SDR-11 (.095)	5/8" OD	9943-99-0066-00‡



- **For sizes not listed, contact Continental Industries.**
- Con-Stab ID Seal® fittings rated at 125 psig.
- Recommended accessories;
  - Continental's Bladed Chamfering Tool. See page 31 for size combinations available.
- 45° Copper Flare made in accordance with SAE J513.
- Forged Flare nut made to ASTM B 283.
- ‡ = IAPMO/UPC Listed



# CON-STAB ID SEAL® FITTINGS



## CON-STAB ID SEAL® Reducer Couplings

PE SIZE	WALL	PE SIZE	WALL	PART NUMBER (3408/4710)	
3/4" CTS (7/8" OD)	.090	1/2" CTS (5/8" OD)	.090	3259-54-0604-00	
1" CTS (1 1/8" OD)	.099/.101	3/4" IPS	SDR-11 (.095)	3259-54-0813-00†	
	.090			3259-54-0813-A0†	
	.099/.101	3/4" CTS (7/8" OD)	.090	3259-54-0806-00	
	.090			3259-54-0806-A0	
	.099/.101	1/2" IPS	SDR-9.33 (.090)	3259-54-0812-00	
	.090			3259-54-0812-A0	
	.099/.101	1/2" CTS (5/8" OD)	.090	3259-54-0804-00†	
.090	3259-54-0804-A0†				
1 1/4" CTS (1 3/8" OD)	.090	1" IPS	SDR-11	3259-54-3914-A0	
		1" CTS (1 1/8" OD)	.099/.101	3259-54-3908-A0	
			.090	3259-54-3908-AA	
		3/4" IPS	SDR-11 (.095)	3259-54-3913-A0	
		3/4" CTS (7/8" OD)	.090	3259-54-3906-A0	
		1/2" IPS	SDR-9.33 (.090)	3259-54-3912-A0	
1/2" IPS	SDR-9.33 (.090)	1/2" CTS (5/8" OD)	.090	3259-54-1204-00	
3/4" IPS	SDR-11 (.095)	1/2" IPS	SDR-9.33 (.090)	3259-54-1312-00†	
		3/4" CTS (7/8" OD)	.090	3259-54-1306-00	
		1/2" CTS (5/8" OD)	.090	3259-54-1304-00†	
1" IPS	SDR-11 (.119)	1" CTS (1 1/8" OD)	.099/.101	3259-54-1408-00†	
			.090	3259-54-1408-0A	
		3/4" IPS	SDR-11 (.095)	3259-54-1413-00†	
		3/4" CTS (7/8" OD)	.090	3259-54-1406-00	
		1/2" IPS	SDR-9.33 (.090)	3259-54-1412-00	
		1/2" CTS	.090	3259-54-1404-00†	
1 1/4" IPS	SDR-10 (.166)	1 1/4" IPS	SDR-11 (.151)	3259-54-1515-0A	
	SDR-11 (.151)	1 1/4" CTS (1 3/8" OD)	.090	3259-54-1539-AA	
	SDR-10 (.166)	1" IPS	SDR-11 (.119)	3259-54-1514-00†	
	SDR-11 (.151)			3259-54-1514-A0	
	SDR-10 (.166)	1" CTS (1 1/8" OD)	.099/.101	3259-54-1508-00†	
				.090	3259-54-1508-0A
	SDR-11 (.151)			.099/.101	3259-54-1508-A0
	SDR-10 (.166)	3/4" IPS	SDR-11 (.095)	3259-54-1513-00†	
SDR-11 (.151)	3259-54-1513-A0				
1 1/2" IPS	SDR-11 (.173)	1 1/4" IPS	SDR-10 (.166)	3369-54-1615-00†*	
2" IPS	SDR-11	1 1/2" IPS	SDR-11 (.173)	3259-54-1716-00†	
		1 1/4" IPS	SDR-10 (.166)	3369-54-1715-00*	
			SDR-11 (.151)	3259-54-1715-0A	
		1 1/4" CTS (1 3/8" OD)	.090	3259-54-1739-0A	
		1" IPS	SDR-11 (.119)	3259-54-1714-00	
		1" CTS (1 1/8" OD)	.099/.101	3259-54-1708-00	
			.090	3259-54-1708-0A	

- For sizes not listed, contact Continental Industries.
- Con-Stab ID Seal® fittings rated at 125 psig.
- Recommended accessories;
  - Continental's Bladed Chamfering Tool. See page 31 for size combinations available.
- † = CSA Approved / ‡ = IAPMO/UPC Listed
- \* = These fittings are only available in PE 2406 yellow.



# CON-STAB ID SEAL® FITTINGS

## CON-STAB ID SEAL® 3-Way Reducing Tees



PE SIZE (Run)	WALL	PE SIZE (Branch)	WALL	PART NUMBER (3408/4710)	PART NUMBER (2406)
1/2" CTS (5/8" OD)	.090	1" CTS (1 1/8" OD)	.099/.101	3259-49-0408-00	3369-49-0408-00
		1" CTS (1 1/8" OD)	.090	3259-49-0408-0A	3369-49-0408-0A
		3/4" IPS	SDR-11 (.095)	3259-49-0413-00	3369-49-0413-00
3/4" CTS (7/8" OD)	.090	1/2" CTS (5/8" OD)	.090	3259-49-0604-00	3369-49-0604-00
1" CTS (1 1/8" OD)	.099/.101 .090 .099/.101 .090	3/4" CTS (7/8" OD)	.090	3259-49-0806-00	3369-49-0806-00
				3259-49-0806-A0	3369-49-0806-A0
		1/2" CTS (5/8" OD)	.090	3259-49-0804-00 ‡	3369-49-0804-00
				3259-49-0804-A0	3369-49-0804-A0
1 1/4" CTS (1 3/8" OD)	.090	1/2" CTS (5/8" OD)	.090	3259-49-3904-A0	3369-49-3904-A0
1/2" IPS	SDR-9.33 (.090)	1/2" CTS (5/8" OD)	.090	3259-49-1204-00	3369-49-1204-00
3/4" IPS	SDR-11 (.095)	1/2" CTS (5/8" OD)	.090	3259-49-1304-00 ‡	3369-49-1304-00
1" IPS	SDR-11 (.119)	1" CTS (1 1/8" OD)	.099/.101	3259-49-1408-00	3369-49-1408-00
			.090	3259-49-1408-0A	3369-49-1408-0A
		3/4" IPS	SDR-11 (.095)	3259-49-1413-00 ‡	3369-49-1413-00
		3/4" CTS (7/8" OD)	.090	3259-49-1406-00	3369-49-1406-00
		1/2" IPS	SDR-9.33 (.090)	3259-49-1412-00	3369-49-1412-00
		1/2" CTS	.090	3259-49-1404-00 ‡	3369-49-1404-00
1 1/4" IPS	SDR-10 (.166)	1" CTS (1 1/8" OD)	.099/.101	NOT AVAILABLE	3369-49-1508-00
			.090	NOT AVAILABLE	3369-49-1508-0A
	SDR-11 (.151)	1" CTS (1 1/8" OD)	.099/.101	3259-49-1508-A0	NOT AVAILABLE
			.090	3259-49-1508-AA	NOT AVAILABLE
	SDR-10 (.166) SDR-11 (.151) SDR-10 (.166) SDR-11 (.151)	3/4" IPS	SDR-11 (.095)	NOT AVAILABLE	3369-49-1513-00
				3259-49-1513-A0	NOT AVAILABLE
				NOT AVAILABLE	3369-49-1504-00
SDR-11 (.151)	1/2" CTS (5/8" OD)	.090	3259-49-1504-A0	NOT AVAILABLE	
			NOT AVAILABLE	3369-49-1504-00	
1 1/2" IPS	SDR-11 (.173)	1 1/4" IPS	SDR-10 (.166)	Not Available	3369-49-1615-00
			SDR-11 (.151)	3259-49-1615-0A	Not Available
2" IPS	SDR-11	1 1/2" IPS	SDR-11 (.173)	3259-49-1716-00 ‡	3369-49-1716-00
		1 1/4" IPS	SDR-10 (.166)	Not Available	3369-49-1715-00
		1" IPS	SDR-11 (.151)	3259-49-1715-0A	Not Available
		1" IPS	SDR-11 (.119)	3259-49-1714-00	3369-49-1714-00
		1" CTS (1 1/8" OD)	.099/.101	3259-49-1708-00 ‡	3369-49-1708-00
			.090	3259-49-1708-0A	3369-49-1708-0A

- For sizes not listed, contact Continental Industries.
- Con-Stab ID Seal® fittings rated at 125 psig.
- Recommended accessories;
  - Continental's Bladed Chamfering Tool. See page 31 for size combinations available.
- ‡ = IAPMO/UPC Listed

**CON-STAB ID SEAL® FITTINGS**

## CON-STAB ID SEAL® Repair Couplings



PE SIZE	WALL	LENGTH	PART NUMBER (3408/4710)	PART NUMBER (2406)
1/2" CTS (5/8" OD)	.090	8"	0459-56-0800-00	0469-56-0800-00
		12"	0459-56-1200-00‡	0469-56-1200-00‡
		24"	0459-56-2400-00	0469-56-2400-00
3/4" CTS (7/8" OD)	.090	8"	0659-56-0800-00	0669-56-0800-00
		12"	0659-56-1200-00	0669-56-1200-00
		24"	0659-56-2400-00	0669-56-2400-00
1" CTS (1 1/8" OD)	.099/.101	8"	0859-56-0800-00	0869-56-0800-00
		12"	0859-56-1200-00‡	0869-56-1200-00‡
		24"	0859-56-2400-00	0869-56-2400-00
	.090	8"	0859-56-0800-AA	0869-56-0800-AA
		12"	0859-56-1200-AA‡	0869-56-1200-AA‡
		24"	0859-56-2400-AA	0869-56-2400-AA
1 1/4" CTS (1 3/8" OD)	.090	8"	3959-56-0800-AA	3969-56-0800-AA
		12"	3959-56-1200-AA	3969-56-1200-AA
		24"	3959-56-2400-AA	3969-56-2400-AA
1/2" IPS	SDR-9.33 (.090)	8"	1259-56-0800-00	1269-56-0800-00
		12"	1259-56-1200-00	1269-56-1200-00
		24"	1259-56-2400-00	1269-56-2400-00
3/4" IPS	SDR-11 (.095)	8"	1359-56-0800-00	1369-56-0800-00
		12"	1359-56-1200-00‡	1369-56-1200-00‡
		24"	1359-56-2400-00	1369-56-2400-00
1" IPS	SDR-11 (.119)	8"	1459-56-0800-00	1469-56-0800-00
		12"	1459-56-1200-00‡	1469-56-1200-00‡
		24"	1459-56-2400-00	1469-56-2400-00

- **For sizes not listed, contact Continental Industries.**
- Con-Stab ID Seal® fittings rated at 125 psig.
- Recommended accessories;
  - Continental's Bladed Chamfering Tool. See page 31 for size combinations available.
- For 1 1/4" IPS and 2" IPS Repair Couplings, see Scope® Repair Couplings on pg 10.
- ‡ = IAPMO/UPC Listed





# SCOPE® REPAIR FITTINGS

## THE SCOPE® Expandable Repair Joint

Call it a pipe stretcher if you'd like. We call it The Scope®—the new, safe solution for quicker and easier repairs and main extensions, exclusively from Continental!

The innovative design of The Scope® compresses to fit a removed section of piping. Just put it in place and extend it for the final connection—with the versatility of Con-Stab I.D. Seal® fittings, or butt fused joints.

Think of it! You can now enjoy great savings in time, labor and money with

each repair, while delivering a greater margin of safety for installers and long-term reliable service!



excavate less. And with its durable all-plastic construction, you don't need cathodic protection.

Most of all, The Scope® is safe and reliable. It meets or exceeds ASTM and DOT requirements. It's designed to operate at the MAOP of any PE piping system. And it comes pre-air tested to allow complete compliance and documentation of every repair.

Available in a variety of sizes. Contact Continental today for more information about The Scope®—the closest thing to a pipe stretcher you'll ever find.

Plus, The Scope® features even more: Telescoping action affords a larger margin of error on cut outs. You

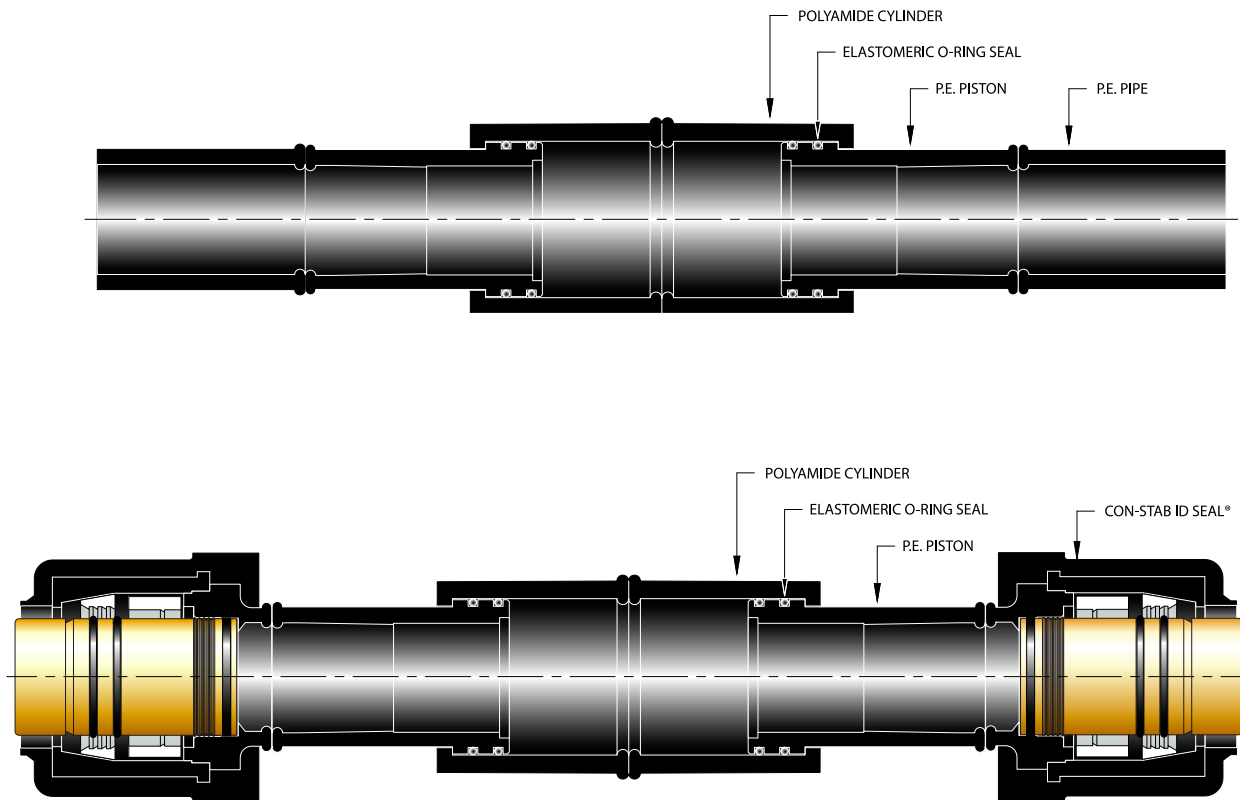

# SCOPE® REPAIR FITTINGS



## THE SCOPE® Expandable Repair Couplings



PE SIZE	WALL	STYLE OUTLET	LENGTH	PART NUMBER (3408/4710)	PART NUMBER (2406)	ACTUAL REPAIR LENGTH
3/4" CTS (7/8" OD)	.090	Con-Stab	14"	3238-14-4406-00	N/A	13 1/2" to 14"
		Con-Stab	26"	3238-26-4406-00	3338-26-4606-00	25 1/2" to 26"
1" CTS (1 1/8" OD)	.099/.101	Con-Stab	14"	3238-14-4408-00	N/A	13 1/2" to 14"
		Con-Stab	26"	3238-26-4408-00	3338-26-4608-00	25 1/2" to 26"
	.090	Con-Stab	14"	3238-14-4408-AA	N/A	13 1/2" to 14"
		Con-Stab	26"	3238-26-4408-AA	3338-26-4608-AA	25 1/2" to 26"
1/2" IPS	SDR-9.3 (.090)	Con-Stab	14"	3238-14-4412-00	N/A	13 1/2" to 14"
		Con-Stab	26"	3238-26-4412-00	3338-26-4612-00	25 1/2" to 26"
3/4" IPS	SDR-11 (.095)	Con-Stab	14"	3238-14-4413-00	N/A	13 1/2" to 14"
		Con-Stab	26"	3238-26-4413-00	3338-26-4613-00	25 1/2" to 26"
1" IPS	SDR-11 (.119)	Con-Stab	14"	3238-14-4414-00	N/A	13 1/2" to 14"
		Con-Stab	26"	3238-26-4414-00	3338-26-4614-00	25 1/2" to 26"
1 1/4" IPS	SDR-10 (.166)	Con-Stab	14"	3238-14-4415-00 ‡	N/A	13 1/2" to 14"
		Con-Stab	26"	N/A	3338-26-4615-00	25 1/2" to 26"
		Con-Stab	38"	N/A	3338-38-4615-00	37 1/2" to 38"
	SDR-11 (.151)	Con-Stab	50"	N/A	3338-50-4615-00	49 1/2" to 50"
		Con-Stab	14"	3238-14-4415-AA	N/A	13 1/2" to 14"
		Con-Stab	26"	3238-26-4415-AA	3338-26-4615-AA	25 1/2" to 26"
1 1/2" IPS	SDR-11 (.173)	Con-Stab	38"	3238-38-4415-AA	3338-38-4615-AA	37 1/2" to 38"
		Con-Stab	50"	3238-50-4415-AA	3338-50-4615-AA	49 1/2" to 50"
		Con-Stab	14"	3238-14-4416-00	N/A	13 1/2" to 14"
		Con-Stab	26"	3238-26-4416-00	3338-26-4616-00	25 1/2" to 26"
2" IPS	SDR-11 (.216)	Con-Stab	38"	3238-38-4416-00	3338-38-4616-00	37 1/2" to 38"
		Con-Stab	50"	3238-50-4416-00	3338-50-4616-00	49 1/2" to 50"
		Con-Stab	14"	3238-14-4417-00 ‡	N/A	13 1/2" to 14"
		Con-Stab	26"	3238-26-4417-00	3338-26-4617-00	25 1/2" to 26"
1 1/4" IPS	SDR-10 (.166)	Con-Stab	38"	3238-38-4417-00	3338-38-4617-00	37 1/2" to 38"
		Con-Stab	50"	3238-50-4417-00	3338-50-4617-00	49 1/2" to 50"
		Fusion	19"	3237-19-4415-00	N/A	16" to 19"
		Fusion	27"	N/A	3337-27-4615-00	16" to 27"
2" IPS	SDR-11 (.216)	Fusion	39"	N/A	3337-39-4615-00	16" to 39"
		Fusion	51"	N/A	3337-51-4615-00	16" to 51"
		Fusion	19"	3237-19-4415-AA	N/A	16" to 19"
		Fusion	27"	3237-27-4415-AA	3337-27-4615-AA	16" to 27"
1 1/4" IPS	SDR-11 (.151)	Fusion	39"	3237-39-4415-AA	3337-39-4615-AA	16" to 39"
		Fusion	51"	3237-51-4415-AA	3337-51-4615-AA	16" to 51"
		Fusion	19"	3237-19-4417-00	N/A	16" to 19"
		Fusion	27"	3237-27-4417-00	3337-27-4617-00	16" to 27"
2" IPS	SDR-11 (.216)	Fusion	39"	3237-39-4417-00	3337-39-4617-00	16" to 39"
		Fusion	51"	3237-51-4417-00	3337-51-4617-00	16" to 51"

- For sizes not listed, contact Continental Industries.
- The Scope® fittings rated at 125 psig.
- Recommended accessories;
  - Continental's Bladed Chamfering Tool. See page 31 for size combinations available.
- ‡ = IAPMO/UPC Listed



# SCOPE® REPAIR FITTINGS

## THE SCOPE® Expandable Repair Couplings (PE Stab X PVC)



PE SIZE	WALL	PVC SOCKET	LENGTH	PART NUMBER (3408/4710)	ACTUAL REPAIR LENGTH
1/2" CTS (5/8" OD)	.090	3/8" IPS	14"	0457-55-0711-34	13 1/2" to 14"
		1/2" IPS	14"	0457-55-0712-34	13 1/2" to 14"
		3/4" IPS	14"	0457-55-0713-34	13 1/2" to 14"
1" CTS (1 1/8" OD)	.099/.101	3/8" IPS	14"	0857-55-0711-34	13 1/2" to 14"
		1/2" IPS	14"	0857-55-0712-34	13 1/2" to 14"
		3/4" IPS	14"	0857-55-0713-34	13 1/2" to 14"
		1" IPS	14"	0857-55-0714-34	13 1/2" to 14"
3/4" IPS	SDR-11 (.095)	3/8" IPS	14"	1357-55-0711-34	13 1/2" to 14"
		1/2" IPS	14"	1357-55-0712-34	13 1/2" to 14"
		3/4" IPS	14"	1357-55-0713-34	13 1/2" to 14"
		1" IPS	14"	1357-55-0714-34	13 1/2" to 14"
1" IPS	SDR-11 (.119)	1" IPS	14"	1457-55-0714-34	13 1/2" to 14"
1 1/4" IPS	SDR-10 (.166)	1" IPS	14"	1557-55-0714-34	13 1/2" to 14"
		1 1/4" IPS	14"	1557-55-0715-34	13 1/2" to 14"
	SDR-11 (.151)	1" IPS	14"	9957-55-0003-00	13 1/2" to 14"
		1 1/4" IPS	14"	9957-55-0001-00	13 1/2" to 14"
2" IPS	SDR-11 (.216)	1 1/4" IPS	14"	1757-55-0715-34	13 1/2" to 14"
		1 1/2" IPS	14"	1757-55-0716-34	13 1/2" to 14"
		2" IPS	14"	1757-55-0717-34	13 1/2" to 14"
		2 1/2" IPS	14"	1757-55-0718-34	13 1/2" to 14"
		3" IPS	14"	1757-55-0719-34	13 1/2" to 14"

- For sizes not listed, contact Continental Industries.
- The Scope® fittings rated at 125 psig.
- Recommended accessories;
  - Continental's Bladed Chamfering Tool. See page 31 for size combinations available.

## THE SCOPE® Expandable Repair Couplings (PE Fusion X PVC)



PE SIZE	WALL	PVC SOCKET	LENGTH	PART NUMBER (3408/4710)	PART NUMBER (2406/2708)	ACTUAL REPAIR LENGTH
1" IPS	SDR-11 (.119)	3/8" IPS	14"	9957-55-0007-00	9957-55-0021-00	13 1/2" to 14"
		1/2" IPS	14"	9957-55-0012-00	9957-55-0022-00	13 1/2" to 14"
		3/4" IPS	14"	9957-55-0008-00	9957-55-0017-00	13 1/2" to 14"
		1" IPS	14"	9957-55-0009-00	9957-55-0013-00	13 1/2" to 14"
1 1/4" IPS	SDR-10 (.166)	3/4" IPS	14"	9957-55-0023-00	9957-55-0019-00	13 1/2" to 14"
		1 1/4" IPS	14"	9957-55-0024-00	9957-55-0014-00	13 1/2" to 14"
	SDR-11 (.151)	1 1/4" IPS	14"	9957-55-0010-00	9957-55-0015-00	13 1/2" to 14"
2" IPS	SDR-11 (.216)	1 1/2" IPS	14"	9957-55-0025-00	9957-55-0020-00	13 1/2" to 14"
		2" IPS	14"	9957-55-0011-00	9957-55-0016-00	13 1/2" to 14"

- For sizes not listed, contact Continental Industries.
- The Scope® fittings rated at 125 psig.

# CON-STAB ID SEAL® ELIMINATORS



## PA CON-STAB ID SEAL® ELIMINATORS Plastic Saddle Punch Tee For Use On All PVC and PE Mains

The changing challenges of today's gas industry demand a better option for making lateral connections to plastic gas pipe. Your absolute best option is now the Eliminator mechanical saddle.

**Faster.** No preparation/set-up time for auxiliary tooling. Installation with the Eliminator mechanical saddle takes just one man only seven minutes, compared to fusion saddles that require two men 30 minutes, to complete an installation. Eliminates the cooling time before removing clamps, before the pressure test, or before tapping the main. Only one tool—a "T" wrench—is required. And auxiliary equipment like generators, extension cords, clamps, scrapers, or special holding fixtures are NOT required.

**Easier.** The Eliminator works on ALL kinds of pipe material...with a simple, consistent assembly process with visual indicators. This assembly does not require complex measurement devices, just easy to follow guidelines. The 3-step installation (bolt, stab and tap) is the simplest yet and the same procedure is used for 3408/4710, 2406, 2306, 3306 or PVC mains. Calibration is NOT required. And finally, the Eliminator easily accommodates field variables like out-of-roundness, coiled pipe, weather, scratches, and pressure testing.

**More Economical.** It isn't hard to figure out that by requiring only one man 7 minutes to install the Eliminator, instead of the usual 2 men spending 30 minutes...the labor savings are significant. Plus there are no long-term maintenance costs of equipment and reduced training costs.

**Safer.** With the Eliminator, there's no chance of shocks from electrical equipment, chance of burns from heater plates, and no difficulties often experienced with pressured piping.

**Superior Dependability.** The Eliminator remains the market leader since its development in 1968. The Eliminator has been successfully installed millions of times...millions. The superior design ensures safe operations at elevated internal pressures and the ability to exceed all requirements of ASTM F 1924. And you can count on the Eliminator connection to endure in the most severe environmental conditions.

Choose the Eliminator or else forget about enjoying superior time and cost savings, reduced safety risks, and one of the industry's highest performance reputations.

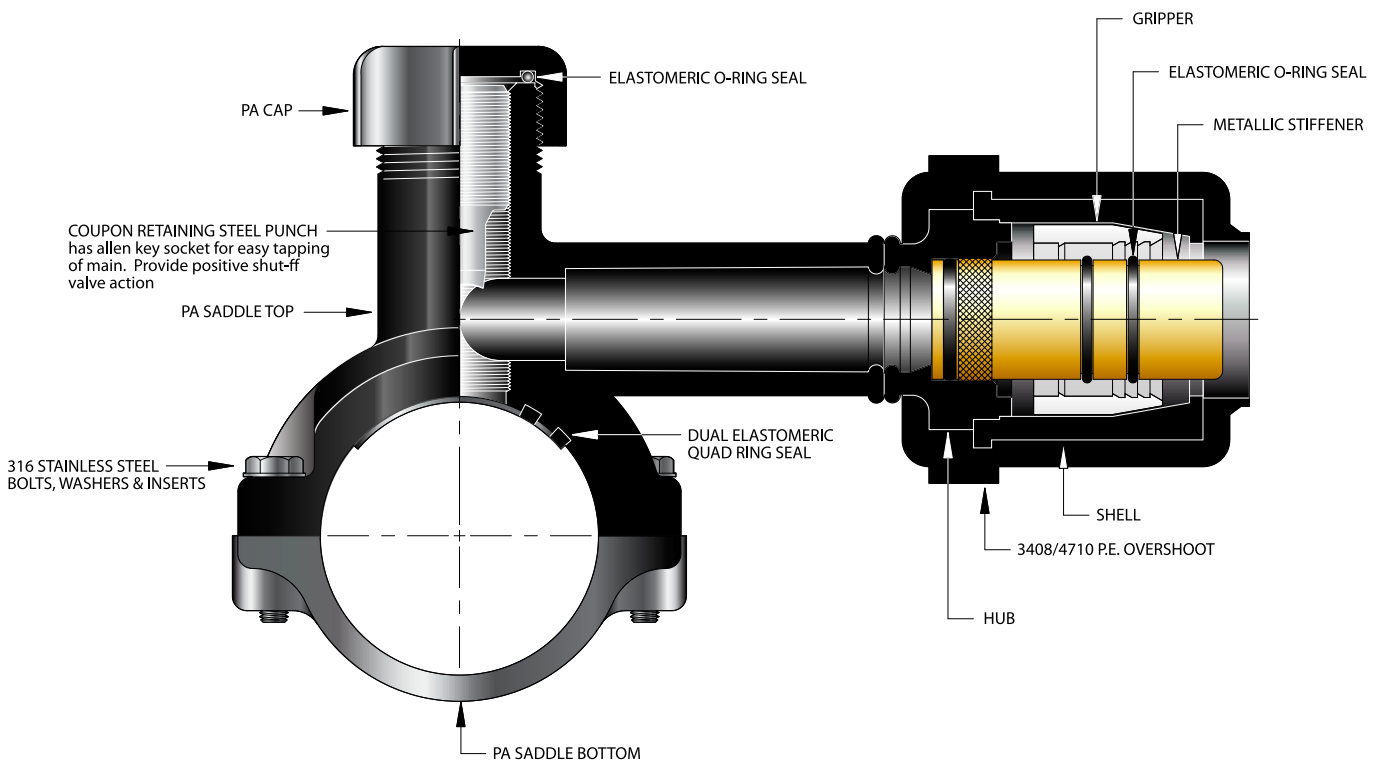



# CON-STAB ID SEAL® ELIMINATORS

## CON-STAB ID SEAL® ELIMINATORS

OUTLET (PE SIZE)	WALL	MAIN SIZE	PART NUMBER	
			5864 1/2" CR PUNCH	5764 13/16" CR PUNCH
1/2" CTS (5/8" OD)	.090	1 1/4"	5864-15-1604-00†	N/A
		2"	5864-17-1604-00‡	5764-17-1604-00†
		3"	5864-19-1604-00	5764-19-1604-00†
		4"	5864-21-1604-00	5764-21-1604-00†
		6"	5864-24-1604-00	5764-24-1604-00†
		8"	N/A	5764-26-1604-00
3/4" CTS (7/8" OD)	.090	1 1/4"	5864-15-1606-00	N/A
		2"	5864-17-1606-00	5764-17-1606-00
		3"	5864-19-1606-00	5764-19-1606-00
		4"	5864-21-1606-00	5764-21-1606-00
		6"	5864-24-1606-00	5764-24-1606-00
		8"	N/A	5764-26-1606-00
1" CTS (1 1/8" OD)	.099/.101	1 1/4"	5864-15-1608-00	N/A
		2"	5864-17-1608-00	5764-17-1608-00
		3"	5864-19-1608-00	5764-19-1608-00
		4"	5864-21-1608-00	5764-21-1608-00
		6"	5864-24-1608-00	5764-24-1608-00
		8"	N/A	5764-26-1608-00
	.090	1 1/4"	5864-15-1608-0A	N/A
		2"	5864-17-1608-0A	5764-17-1608-0A
		3"	5864-19-1608-0A	5764-19-1608-0A
		4"	5864-21-1608-0A	5764-21-1608-0A
		6"	5864-24-1608-0A	5764-24-1608-0A
		8"	N/A	5764-26-1608-0A
1/2" IPS	SDR-9.33 (.090)	1 1/4"	5864-15-1612-00	N/A
		2"	5864-17-1612-00	5764-17-1612-00
		3"	5864-19-1612-00	5764-19-1612-00
		4"	5864-21-1612-00	5764-21-1612-00
		6"	5864-24-1612-00	5764-24-1612-00
		8"	N/A	5764-26-1612-00
3/4" IPS	SDR-11 (.095)	1 1/4"	5864-15-1613-00‡	N/A
		2"	5864-17-1613-00‡	5764-17-1613-00†
		3"	5864-19-1613-00	5764-19-1613-00†
		4"	5864-21-1613-00	5764-21-1613-00†
		6"	5864-24-1613-00	5764-24-1613-00†
		8"	N/A	5764-26-1613-00
1" IPS	SDR-11 (.119)	1 1/4"	5864-15-1614-00	N/A
		2"	5864-17-1614-00	5764-17-1614-00†
		3"	5864-19-1614-00	5764-19-1614-00†
		4"	5864-21-1614-00	5764-21-1614-00†
		6"	5864-24-1614-00	5764-24-1614-00†
		8"	N/A	5764-26-1614-00



- For sizes not listed, contact Continental Industries.
- Con-Stab ID Seal® Eliminators rated at 125 psig.
- Recommended accessories;
  - Continental's Bladed Chamfering Tool. See page 31 for size combinations available.
  - 33-5505-00 ~ Combination Tapping Tool & Saddle Bolt "T" Wrench for 1 1/4" thru 6" IPS Eliminators (pg 31)
  - 33-5505-01 ~ Combination Tapping Tool & Saddle Bolt "T" Wrench for 3" thru 8" IPS Eliminators (pg 31)
  - 33-5508-00 ~ Test Plug Cap for Eliminator Saddles (pg 31)
- For Con-Stab ID Seal® Eliminators with EFV's, contact Continental Industries.
- For Protective Sleeves, see page 32.
- † = CSA Approved / ‡ = IAPMO/UPC Listed



33-5505-00 & 33-5505-01~ Combination Tapping Tool & Saddle Bolt "T" Wrench (pg 31)

The Eliminator can be used on a variety of plastic fuel gas piping.

# CON-STAB ID SEAL® ELIMINATORS



## PA HIGH VOLUME TEE (HVT) CON-STAB ID SEAL® ELIMINATORS Plastic Saddle Punch Tee For Use On All PVC and PE Mains

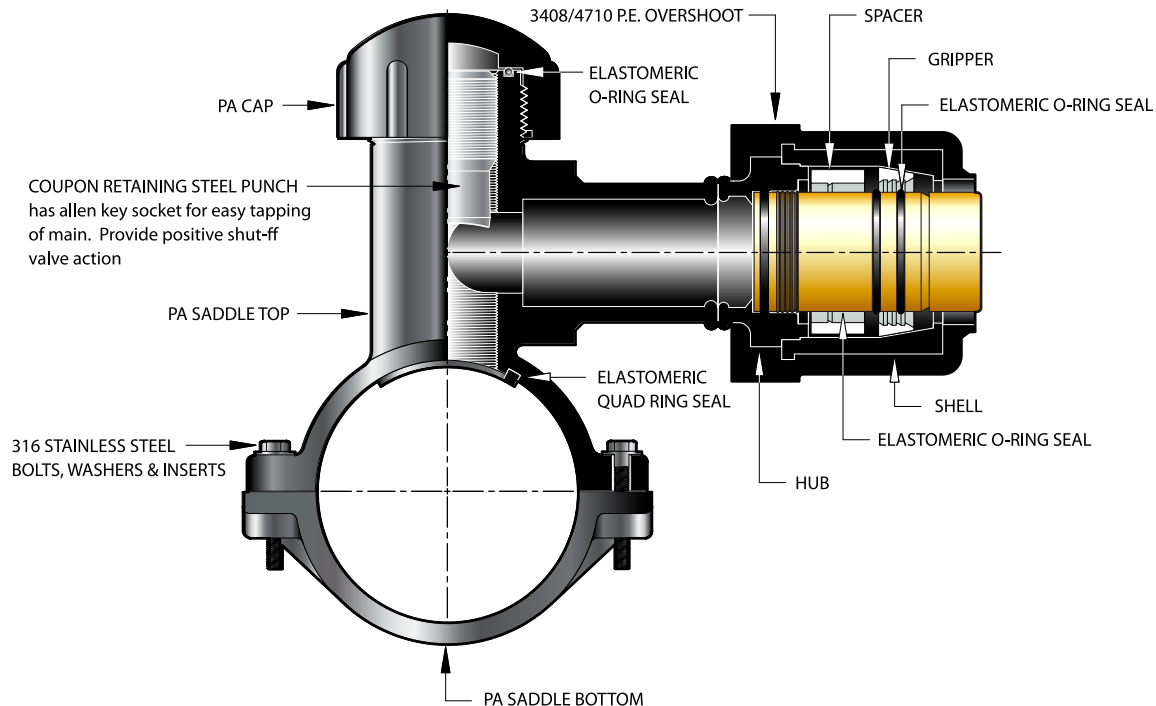

With today's labor and economic conditions, you need a better option for making 1 1/4" and 2" lateral connections to plastic pipe. Continental's PA High Volume Tee is the only mechanical saddle that offers a 1 1/2" coupon retaining punch to minimize flow restrictions and maximize gas flow. Continental's PA High Volume Tee is available for 2", 3", 4", and 6" plastic pipe. Furthermore, you can choose Con-Stab or Compression outlets for your lateral connection.

**Easy to install.** The HVT can be used on a variety of plastic fuel gas piping. Visual indicators make repeatable successful installation a cinch. The 2-stage installation is the simplest yet and the same procedure is used for 3408/4710, 2406, 2306, 3306 or PVC. Calibration is NOT required. And finally, the HVT easily accommodates field variable like out-of-roundness, coiled pipe, weather, and pressure testing.

**Fast.** Whereas fusion saddles require two men approximately 45 minutes to complete an installation of a single tee, installation with the HVT mechanical saddle takes just one man only 10 minutes. There's no cooling time necessary before removing clamps, before the pressure test, or before tapping the main. Auxiliary equipment like computerized controllers, generators, extension cords, clamps, scrapers, or special holding fixtures are NOT required.

**Economical.** It isn't hard to figure out that by requiring only one man 10 minutes to install the HVT, instead of the usual fusion method...the manpower savings are significant. Plus there are no long-term maintenance costs of equipment and reduced training requirements.

**Safe.** With the HVT, there's no chance of shocks from electrical equipment, no chance of burns from heater plates, and no difficulties often experienced with saddle fusions made to pressurized mains.

**Superior Dependability.** The market leader since its development in 1968. The HVT has been successfully installed millions of times...millions. The innovative design and advanced sealing methodology utilized means the extended life of the piping system. And you can count on the HVT connection to endure in the most severe environmental conditions. The superior design ensures safe operations at elevated internal pressures and the ability to exceed all requirements of ASTM F 1924.

For all your high volume lateral connections on plastic pipe, choose the super easy HVT.





# CON-STAB ID SEAL® ELIMINATORS

## CON-STAB ID SEAL® HVT ELIMINATORS

OUTLET (PE SIZE)	WALL	MAIN SIZE	PART NUMBER
1 1/4" IPS	SDR-10 (.166)	2"	5664-17-1615-00
		3"	5664-19-1615-00
		4"	5664-21-1615-00
		6"	5664-24-1615-00
	SDR-11 (.151)	2"	5664-17-1615-0A
		3"	5664-19-1615-0A
4"		5664-21-1615-0A	
2" IPS	SDR-11 (.216)	2"	5664-17-1617-00
		3"	5664-19-1617-00
		4"	5664-21-1617-00
		6"	5664-24-1617-00

- For sizes not listed, contact Continental Industries.
- Con-Stab ID Seal® HVT Eliminators rated at 125 psig.
- Recommended accessories;
  - Continental's Bladed Chamfering Tool. See page 31 for size combinations available.
  - 33-4363-00 ~ 1/2" Square Drive Key, Bushing and Socket Adapter (pg 31)
  - 33-6290-00 ~ Test Plug Cap for Eliminator Saddles (pg 31)
- For Protective Sleeves, see page 32.



33-4363-00 ~ 1/2" Square Drive Key, Bushing and Socket Adapter (pg 31)

- AVAILABLE WITH:
  - 2" to 6" IPS mains
  - Stab or compression outlet
  - 1 1/2" coupon retaining punch
- INCREASED PRESSURE CAPABILITY:
  - All saddles are pressure rated @ 125 psi
  - PA saddles elevated temperature code CE
- POLYAMIDE MATERIAL (PA):
  - Used for 30 years in gas industry
  - Listed material in ASTM D 2513
  - Superior chemical resistance
  - PA is stronger than PE
  - Elevated temperature performance
- FULL CIRCUMFERENTIAL COMPRESSION
  - Stable foundation
  - Rotation resistance
  - Equal stress distribution
  - Simple tapping procedure



The HVT can be used on a variety of plastic fuel gas piping.

# PE VALVE TEES



## POLYETHYLENE VALVE TEE For Use On Cast Iron Mains

The polyethylene valve tee provides a new efficient method of attaching services to cast iron mains. The polyethylene valve tee can be attached to any size metallic main through standard drill and tap operations. The valve tee incorporates corrosion resistant materials (brass and polyethylene). The innovative design provides a low profile tee which makes it less vulnerable to damage. Each valve tee utilizes a threaded internal plug for gas shut off and a brass base that can be swivelled 360° to simplify the connection to the service. The valve tee design has been tested to meet or exceed all D.O.T. and ASTM requirements and can be operated at 75 psig. All of these features combine to provide the most cost effective method for attaching polyethylene services to cast iron mains.

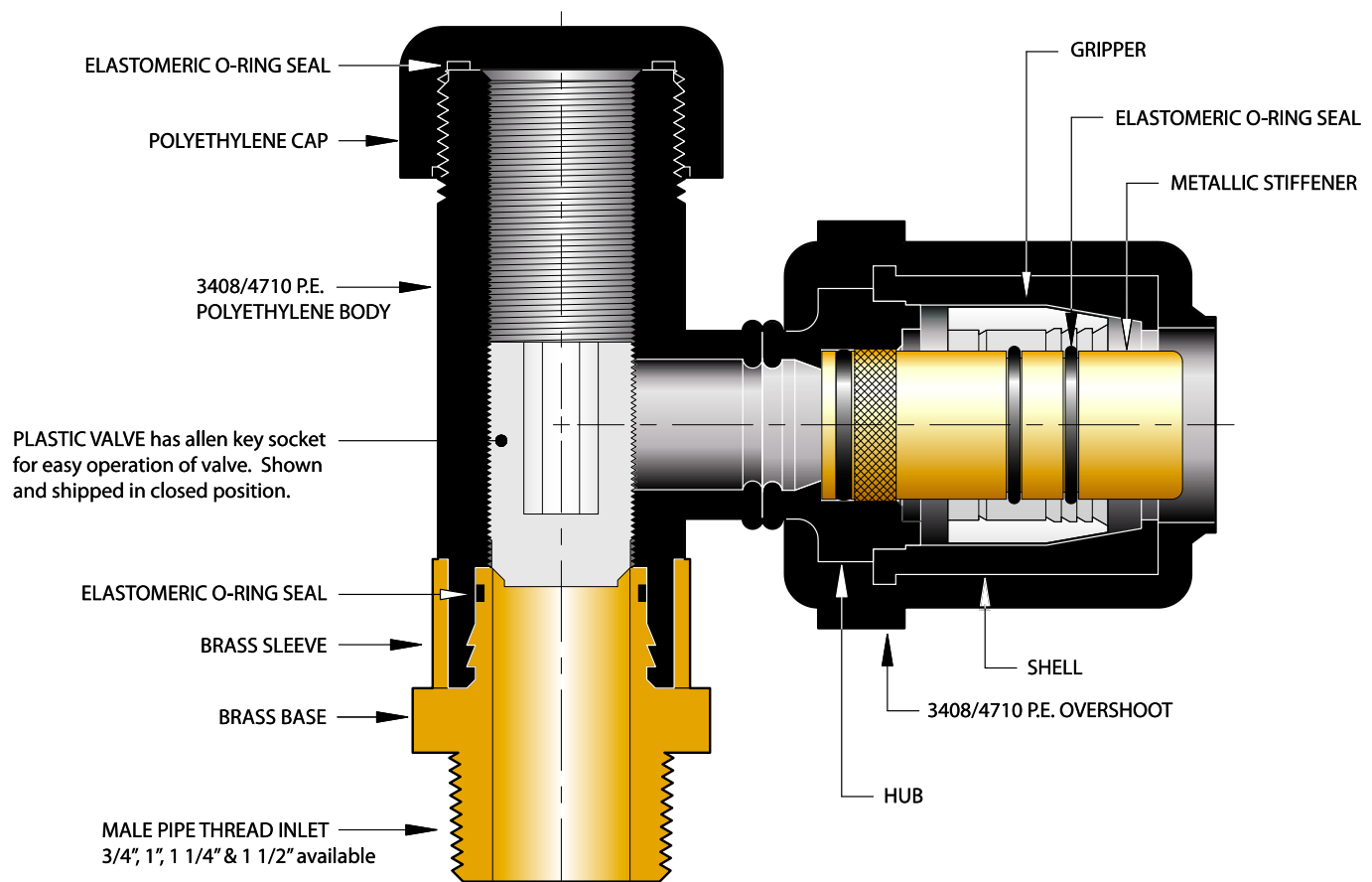

- AVAILABLE WITH A CON-STAB ID SEAL® OR BUTT FUSION OUTLET
- CORROSION RESISTANT
- MEETS OR EXCEEDS ALL D.O.T. AND ASTM REQUIREMENTS
- ASTM B62 BRASS SLEEVE AND BASE
- CAN BE ROTATED 360° AFTER BEING INSTALLED ON MAIN
- ASSEMBLED READY TO INSTALL
- CAN WITHSTAND 150 PSI AIR TEST WITH NO LEAK TO THE MAIN



# PE VALVE TEES

## PE VALVE TEE For Use On Metallic Mains

OUTLET (PE SIZE)	WALL	INLET SIZE	PART NUMBER (3408/4710)
1/2" CTS (5/8" OD)	.090	3/4"	1332-11-1604-00
		1"	1432-11-1604-00
		1 1/4"	1532-11-1604-00
		1 1/2"	1632-11-1604-00
3/4" CTS (7/8" OD)	.090	3/4"	1332-11-1606-00
		1"	1432-11-1606-00
		1 1/4"	1532-11-1606-00
		1 1/2"	1632-11-1606-00
1" CTS (1 1/8" OD)	.099/.101	3/4"	1332-11-1608-00
		1"	1432-11-1608-00
		1 1/4"	1532-11-1608-00
		1 1/2"	1632-11-1608-00
	.090	3/4"	1332-11-1608-0A
		1"	1432-11-1608-0A
		1 1/4"	1532-11-1608-0A
		1 1/2"	1632-11-1608-0A
1 1/4" CTS (1 3/8" OD)	.090	3/4"	1332-11-1639-0A
		1"	1432-11-1639-0A
		1 1/4"	1532-11-1639-0A
		1 1/2"	1632-11-1639-0A
1/2" IPS	SDR-9.33 (.090)	3/4"	1332-11-1612-00
		1"	1432-11-1612-00
		1 1/4"	1532-11-1612-00
		1 1/2"	1632-11-1612-00
3/4" IPS	SDR-11 (.095)	3/4"	1332-11-1613-00
		1"	1432-11-1613-00
		1 1/4"	1532-11-1613-00
		1 1/2"	1632-11-1613-00
1" IPS	SDR-11 (.119)	3/4"	1332-11-1614-00
		1"	1432-11-1614-00
		1 1/4"	1532-11-1614-00
		1 1/2"	1632-11-1614-00



- For sizes not listed, contact Continental Industries.
- PE Valve Tees rated at 75 psig.
- Recommended accessories;
  - Continental's Bladed Chamfering Tool. See page 31 for size combinations available.
- For Protective Sleeves, see page 32.



Contact Continental Industries about PE Valve Tees with a Con-Stab ID Seal® Swing Joint.

# TRANSITION FITTINGS



## TRANSITION FITTINGS Polyethylene Pipe x Pipe Thread For Joining Polyethylene Pipe To Metallic Pipe

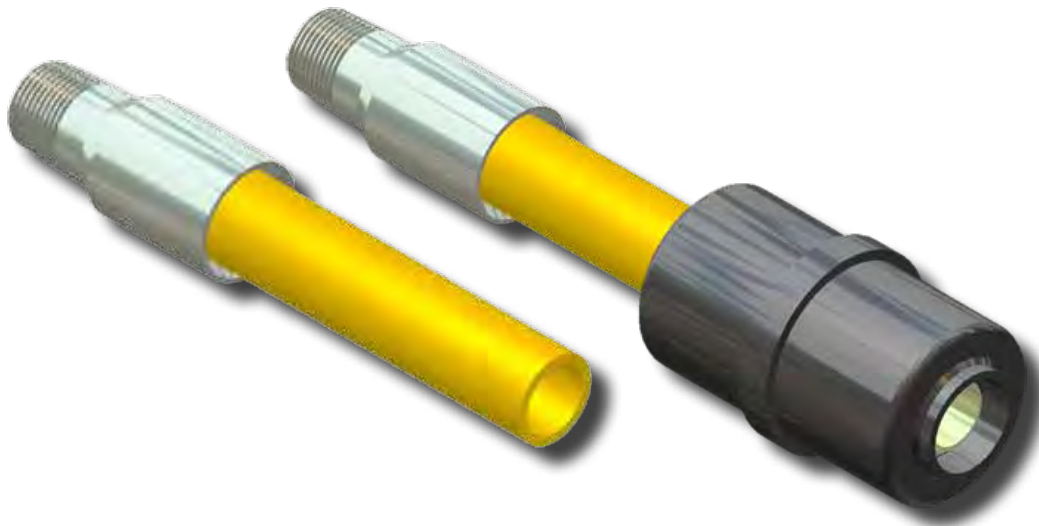
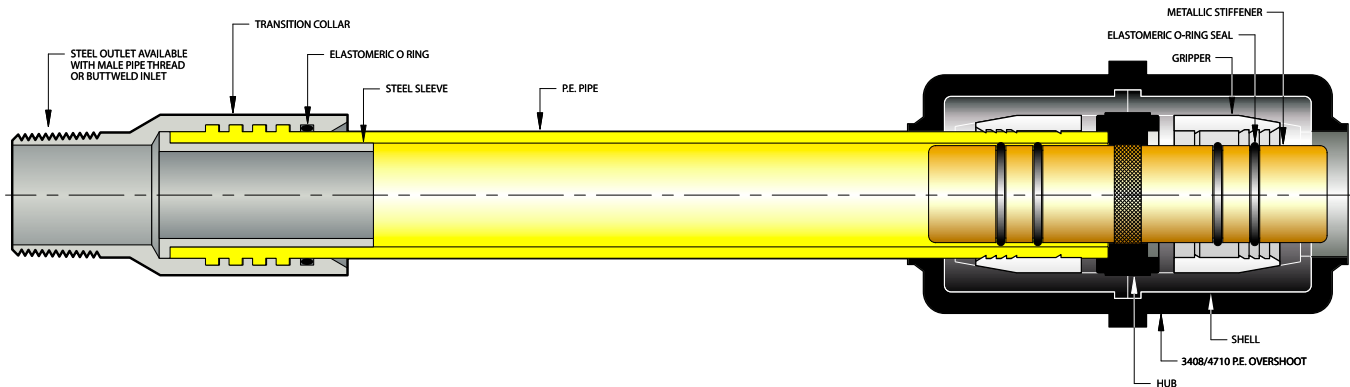

- O-RING SEAL PROVIDES POSITIVE SEAL
- ZINC PLATED FOR CORROSION PROTECTION
- MECHANICALLY HELD - PROVIDES MAXIMUM PULL-OUT RESISTANCE—tensile strength exceeds requirements of D.O.T., Title 49 of the Code of Federal Regulations, Part 192.283 (b)
- AVAILABLE WITH 2406 OR 3408/4710 P.E. EXTENSIONS
- CONFORMS TO ASTM D2513, & ANSI B31.8 & DOT 192.121
- AVAILABLE WITH MALE PIPE THREADED END



# TRANSITION FITTINGS

## TRANSITION FITTINGS

OUTLET	WALL	INLET	PART NUMBER 2406	PART NUMBER 3408/4710	OVERALL LENGTH
1/2" CTS (5/8" OD)	.090	1/2" MPT	4646-00-1904-00†‡	4949-00-1904-00‡	14 3/8"
1" CTS (1 1/8" OD)	.099/.101	1" MPT	4646-00-1908-00†‡	4949-00-1908-00‡	14 3/4"
1/2" IPS	SDR-9.33 (.090)	3/4" MPT	4646-00-1912-00‡	4949-00-1912-00‡	14 11/32"
3/4" IPS	SDR-11 (.095)	3/4" MPT	4646-00-1913-00†‡	4949-00-1913-00‡	15"
1" IPS	SDR-11 (.119)	1" MPT	4646-00-1914-00†‡	4949-00-1914-00‡	16 1/8"
1 1/4" IPS	SDR-10 (.166)	1 1/4" MPT	4646-00-1915-00†‡	Not Available	16 1/16"
1 1/4" IPS	SDR-11 (.151)	1 1/4" MPT	4646-00-1915-0A†‡	4949-00-1915-0A‡	16 1/16"
1 1/2" IPS	SDR-11 (.171)	1 1/2" MPT	4646-00-1916-00†‡	4949-00-1916-00‡	16 5/16"
2" IPS	SDR-11 (.166)	2" MPT	4646-00-1917-00†‡	4949-00-1917-00‡	16 11/16"

- For sizes not listed, contact Continental Industries.
- Transition fittings rated at 125 psig.
- † = CSA Approved / ‡ = IAPMO/UPC Listed



## CON-STAB ID SEAL® STEEL TRANSITION FITTINGS

OUTLET (PE SIZE)	WALL	INLET	PART NUMBER 2406	PART NUMBER 3408/4710	OVERALL LENGTH
1/2" CTS (5/8" OD)	.090	1/2" MPT	4646-00-1904-25†‡	4949-00-1904-25‡	16 9/16"
1" CTS (1 1/8" OD)	.099/.101	1" MPT	4646-00-1908-25†‡	4949-00-1908-25‡	16 15/16"
1/2" IPS	SDR-9.33 (.090)	3/4" MPT	4646-00-1912-25‡	4949-00-1912-25‡	16 9/16"
3/4" IPS	SDR-11 (.095)	3/4" MPT	4646-00-1913-25†‡	4949-00-1913-25‡	17 3/16"
1" IPS	SDR-11 (.119)	1" MPT	4646-00-1914-25†‡	4949-00-1914-25‡	19 1/4"
1 1/4" IPS	SDR-10 (.166)	1 1/4" MPT	4646-00-1915-25†‡	Not Available	19 3/16"
1 1/4" IPS	SDR-11 (.151)	1 1/4" MPT	9946-00-0058-25†‡	9949-00-0001-25‡	19 3/16"
1 1/2" IPS	SDR-11 (.171)	1 1/2" MPT	4646-00-1916-25†‡	4949-00-1916-25‡	19 7/16"
2" IPS	SDR-11 (.166)	2" MPT	4646-00-1917-25†‡	4949-00-1917-25‡	19 13/16"

- For sizes not listed, contact Continental Industries.
- Con-Stab ID Seal® fittings rated at 125 psig.
- Recommended accessories;
  - Continental's Bladed Chamfering Tool. See page 31 for size combinations available.
- † = CSA Approved / ‡ = IAPMO/UPC Listed



## CON-STAB ID SEAL® BRASS TRANSITION FITTINGS

OUTLET (PE SIZE)	WALL	INLET	PART NUMBER (3408/4710)
1/2" CTS (5/8" OD)	.090	1/2" MPT	9932-00-0002-00
		1/2" FPT	9932-00-0019-00
		3/4" MPT	9932-00-0004-00
		3/4" FPT	9932-00-0021-00
1" CTS (1 1/8" OD)	.099/.101	3/4" MPT	9932-00-0008-00
		3/4" FPT	9932-00-0025-00
		1" MPT	9932-00-0010-00
		1" FPT	9932-00-0027-00
	.090	3/4" MPT	9932-00-0007-00
		3/4" FPT	9932-00-0024-00
		1" MPT	9932-00-0009-00
		1" FPT	9932-00-0026-00
1/2" IPS	SDR-9.33 (.090)	1/2" MPT	9932-00-0013-00
		1/2" FPT	9932-00-0030-00
		3/4" MPT	9932-00-0014-00
		3/4" FPT	9932-00-0031-00
3/4" IPS	SDR-11 (.095)	3/4" MPT	9932-00-0015-00
		3/4" FPT	9932-00-0032-00
		1" MPT	9932-00-0016-00
		1" FPT	9932-00-0033-00

- For sizes not listed, contact Continental Industries.
- Con-Stab ID Seal® fittings rated at 125 psig.
- Recommended accessories;
  - Continental's Bladed Chamfering Tool. See page 31 for size combinations available.



# PA COMPRESSION FITTINGS



## PA COMPRESSION FITTINGS

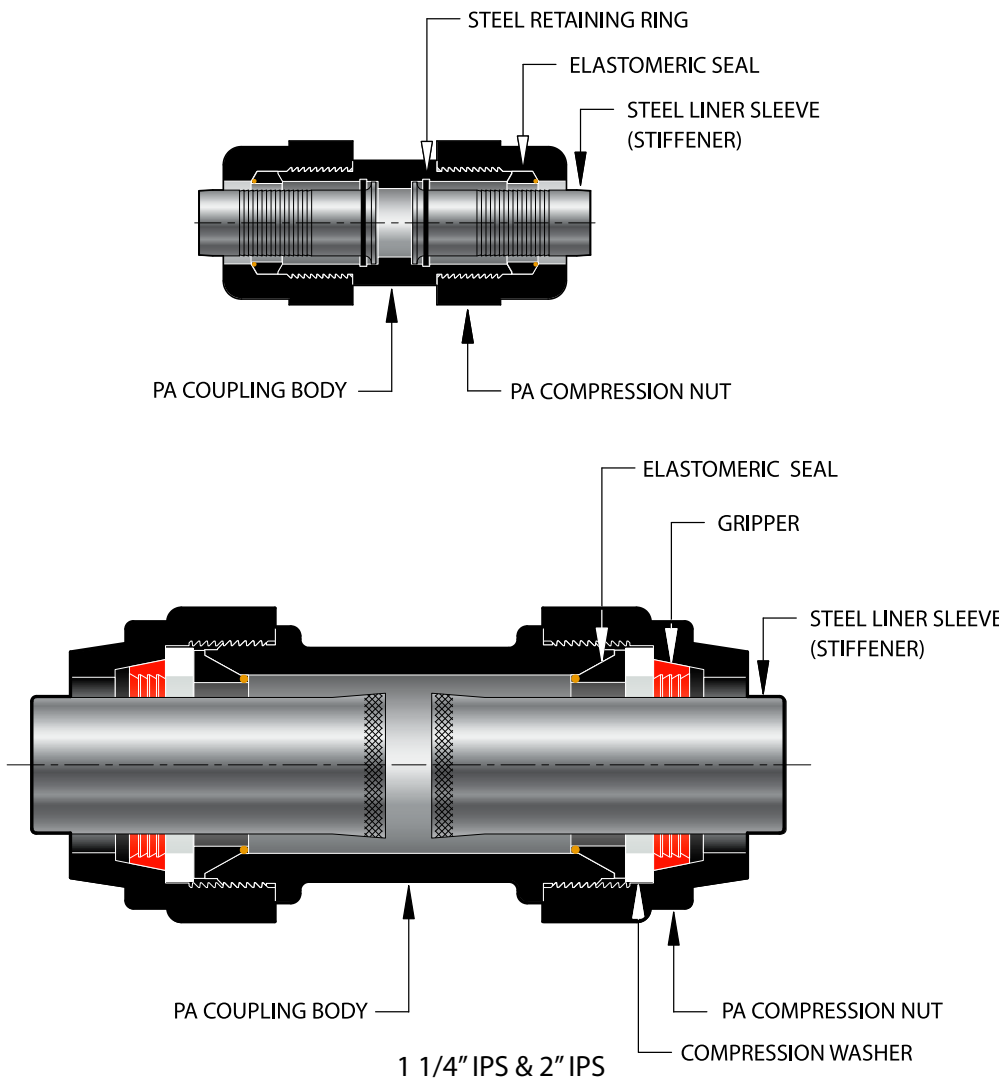

- **QUICKLY AND EASILY INSTALLED**—because it's pre-assembled. Just insert tubing and tighten compression nut (except for 1 1/4" & 2" IPS, see instructions on shipping bag).
- **PA COMPRESSION FITTINGS**—can be used on a variety of polyethylene fuel gas piping. Visual indicators make repeatable and successful installation a cinch. The installation is simple and the same procedure is used for 3408/4710, 2406, 2306 or 3306 PE.
- **DESIGNED FOR MAXIMUM PULL-OUT STRENGTH**—tensile strength exceeds requirements of D.O.T., Title 49 of the Code of Federal Regulations, Part 192.283 (b)
- **PERMANENT LEAK-PROOF JOINT**
- **ECONOMICAL AND EXTREMELY VERSATILE**
- **GASKET FULLY RETAINED TO PREVENT COLD FLOW**
- Reference Instruction Sheet 34-4834-92 for 1/2" CTS through 1" IPS and 34-4834-32 for 1 1/4" & 2" IPS couplings for proper installation.





# PA COMPRESSION FITTINGS



## PA COMPRESSION FITTINGS Full Couplings

PE SIZE	WALL	PART NUMBER
1/2" CTS (5/8" OD)	.090	5657-52-1004-00‡
	.062	5657-52-1004-AA
1" CTS (1 1/8" OD)	.099/.101	5657-52-1008-00
	.090	5657-52-1008-AA
3/4" IPS	SDR-11 (.095)	5657-52-1013-00
1" IPS	SDR-11 (.119)	5657-52-1014-00
1 1/4" IPS	SDR-10 (.166)	5657-52-1015-00
	SDR-11 (.151)	5657-52-1015-AA
2" IPS	SDR-11 (.216)	5657-52-1017-00

- For sizes not listed, contact Continental Industries.
- PA Compression fittings rated at 125 psig.
- For PA Couplings with EFV's, contact Continental Industries.
- ‡ = IAPMO/UPC Listed



## PA COMPRESSION FITTINGS End Caps

PE SIZE	WALL	PART NUMBER
1/2" CTS (5/8" OD)	.090	5657-53-1004-00
	.062	5657-53-1004-0A
1" CTS (1 1/8" OD)	.099/.101	5657-53-1008-00
	.090	5657-53-1008-0A
3/4" IPS	SDR-11 (.095)	5657-53-1013-00
1" IPS	SDR-11 (.119)	5657-53-1014-00
1 1/4" IPS	SDR-10 (.166)	5657-53-1015-00
	SDR-11 (.151)	5657-53-1015-0A
2" IPS	SDR-11 (.216)	5657-53-1017-00

- For sizes not listed, contact Continental Industries.
- PA Compression fittings rated at 125 psig.



## PA COMPRESSION FITTINGS 3-Way Tees

PE SIZE	WALL	PART NUMBER
1/2" CTS (5/8" OD)	.090	5657-50-1004-00
	.062	5657-50-1004-AA
1" CTS (1 1/8" OD)	.099/.101	5657-50-1008-00
	.090	5657-50-1008-AA
3/4" IPS	SDR-11 (.095)	5657-50-1013-00

- For sizes not listed, contact Continental Industries.
- PA Compression fittings rated at 125 psig.



## PA COMPRESSION FITTINGS 90° Elbows

PE SIZE	WALL	PART NUMBER
1/2" CTS (5/8" OD)	.090	5657-51-1004-00
	.062	5657-51-1004-AA
1" CTS (1 1/8" OD)	.099/.101	3259-51-1008-00
	.090	5657-51-1008-AA
3/4" IPS	SDR-11 (.095)	5657-51-1013-00

- For sizes not listed, contact Continental Industries.
- PA Compression fittings rated at 125 psig.

## PA COMPRESSION FITTINGS Reducer Couplings

PE SIZE	WALL	PE SIZE	WALL	PART NUMBER
1/2" CTS (5/8" OD)	.090	1/2" CTS (5/8" OD)	.062	5657-54-0404-0A
		1/4" CTS (3/8" OD)	.062	5657-54-0402-00
1" CTS (1 1/8" OD)	.099/.101	3/4" IPS	SDR-11 (.095)	5657-54-0813-00
				5657-54-0813-A0
	.090	1/2" CTS (5/8" OD)	.062	5657-54-0804-0A
				5657-54-0804-AA
				5657-54-0804-00
				5657-54-0804-A0
3/4" IPS	SDR-11 (.095)	1/2" CTS (5/8" OD)	.090	5657-54-1304-00
				5657-54-1304-0A
1" IPS	SDR-11 (.119)	1" CTS (1 1/8" OD)	.099/.101	5657-54-1408-00
			.090	5657-54-1408-0A
		3/4" IPS	SDR-11 (.095)	5657-54-1413-00
				5657-54-1413-A0
		1/2" CTS	.090	5657-54-1404-00
	.062	5657-54-1404-0A		
1 1/4" IPS	SDR-10 (.166)	1 1/4" IPS	SDR-11 (.151)	5657-54-1015-0A

- For sizes not listed, contact Continental Industries.
- PA Compression fittings rated at 125 psig.



# PA ELIMINATORS



## PA ELIMINATORS Plastic Saddle Punch Tee For Use On PVC and PE Mains

The changing challenges of today's gas industry demand a better option for making lateral connections to plastic gas pipe. Your absolute best option is now the Eliminator mechanical saddle.

**Faster.** No preparation/set-up time for auxiliary tooling. Installation with the Eliminator mechanical saddle takes just one man only seven minutes, compared to fusion saddles that require two men 30 minutes, to complete an installation. Eliminates the cooling time before removing clamps, before the pressure test, or before tapping the main. Only one tool—a "T" wrench—is required. Auxiliary equipment like generators, extension cords, clamps, scrapers, or special holding fixtures are NOT required.

**Easier.** The Eliminator works on ALL kinds of pipe material...with a simple, consistent assembly process with visual indicators. This assembly does not require complex measurement devices, just easy to follow guidelines. The 3-step installation (bolt, stab and tap) is the simplest yet and the same procedure is used for 3408/4710, 2406, 2306, 3306 PE or PVC mains. Calibration is NOT required. And finally, the Eliminator easily accommodates field variables like out-of-roundness, coiled pipe, weather, scratches, and pressure testing.

**More Economical.** It isn't hard to figure out that by requiring only one man 7 minutes to install the Eliminator, instead of the usual 2 men spending 30 minutes...the labor savings are significant. Plus there are no long-term maintenance costs of equipment and reduced training costs.

**Safer.** With the Eliminator, there's no chance of shocks from electrical equipment, chance of burns from heater plates, and no difficulties often experienced with pressured piping.

**Superior Dependability.** The Eliminator remains the market leader since its development in 1968. The Eliminator has been successfully installed millions of times...millions. The superior design ensures safe operations at elevated internal pressures and the ability to exceed all requirements of ASTM F 1924. And you can count on the Eliminator connection to endure in the most severe environmental conditions.

Choose the Eliminator or else forget about enjoying superior time and cost savings, reduced safety risks, and one of the industry's highest performance reputations.

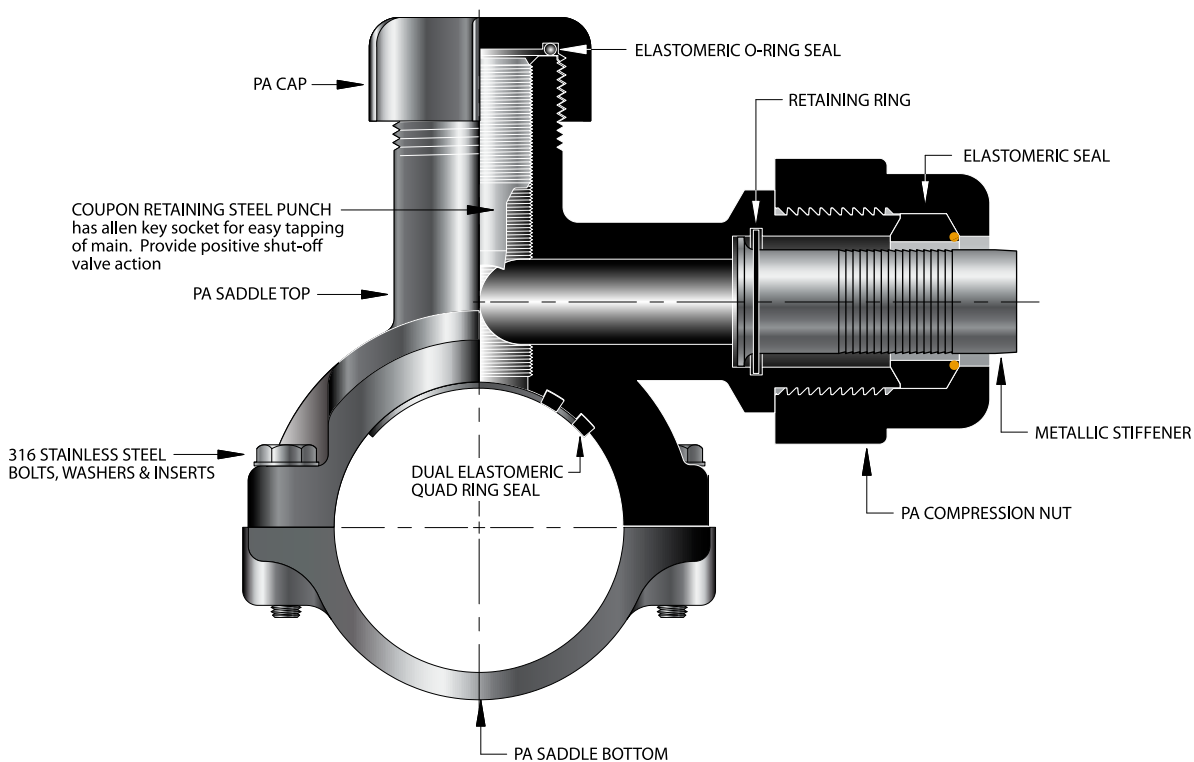



# PA ELIMINATORS

## PA ELIMINATORS

OUTLET (PE SIZE)	WALL	MAIN SIZE	PART NUMBER 5864	PART NUMBER 5764
			1/2" CR PUNCH	13/16" CR PUNCH
1/2" CTS (5/8" OD)	.090	1 1/4"	5864-15-1004-00	N/A
		2"	5864-17-1004-00	5764-17-1004-00
		3"	5864-19-1004-00	5764-19-1004-00
		4"	5864-21-1004-00	5764-21-1004-00
		6"	5864-24-1004-00	5764-24-1004-00
		8"	N/A	5764-26-1004-00
	.062	1 1/4"	5864-15-1004-0A	N/A
		2"	5864-17-1004-0A	5764-17-1004-0A
		3"	5864-19-1004-0A	5764-19-1004-0A
		4"	5864-21-1004-0A	5764-21-1004-0A
		6"	5864-24-1004-0A	5764-24-1004-0A
		8"	N/A	5764-26-1004-0A
1" CTS (1 1/8" OD)	.099/.101	1 1/4"	5864-15-1008-00	N/A
		2"	5864-17-1008-00	5764-17-1008-00
		3"	5864-19-1008-00	5764-19-1008-00
		4"	5864-21-1008-00	5764-21-1008-00
		6"	5864-24-1008-00	5764-24-1008-00
		8"	N/A	5764-26-1008-00
	.090	1 1/4"	5864-15-1008-0A	N/A
		2"	5864-17-1008-0A	5764-17-1008-0A
		3"	5864-19-1008-0A	5764-19-1008-0A
		4"	5864-21-1008-0A	5764-21-1008-0A
		6"	5864-24-1008-0A	5764-24-1008-0A
		8"	N/A	5764-26-1008-0A
3/4" IPS	SDR-11 (.095)	1 1/4"	5864-15-1013-00	N/A
		2"	5864-17-1013-00	5764-17-1013-00
		3"	5864-19-1013-00	5764-19-1013-00
		4"	5864-21-1013-00	5764-21-1013-00
		6"	5864-24-1013-00	5764-24-1013-00
		8"	N/A	5764-26-1013-00
1" IPS	SDR-11 (.119)	1 1/4"	5864-15-1014-00	N/A
		2"	5864-17-1014-00	5764-17-1014-00
		3"	5864-19-1014-00	5764-19-1014-00
		4"	5864-21-1014-00	5764-21-1014-00
		6"	5864-24-1014-00	5764-24-1014-00
		8"	N/A	5764-26-1014-00

- For sizes not listed, contact Continental Industries.
- PA Eliminators are rated at 125 psig.
- Recommended accessories;
  - 33-5505-00 ~ Combination Tapping Tool & Saddle Bolt "T" Wench for 1 1/4" thru 6" IPS Eliminators (pg 31)
  - 33-5505-01 ~ Combination Tapping Tool & Saddle Bolt "T" Wench for 3" thru 8" IPS Eliminators (pg 31)
  - 33-5508-00 ~ Test Plug Cap for Eliminator Saddles (pg 31)
- For PA Eliminators with EFV's, contact Continental Industries.
- For Protective Sleeves, see page 32.



33-5505-00 & 33-5505-01  
Combination Tapping Tool & Saddle Bolt  
"T" Wench (pg 31)

**MECHANICAL SADDLES**  
are the most economical and dependable way to make lateral connections to plastic gas pipe.

The Eliminator can be used on a variety of plastic fuel gas piping.



# PA ELIMINATORS



## PA HIGH VOLUME TEE (HVT) ELIMINATORS Plastic Saddle Punch Tee For Use On PVC and PE Mains

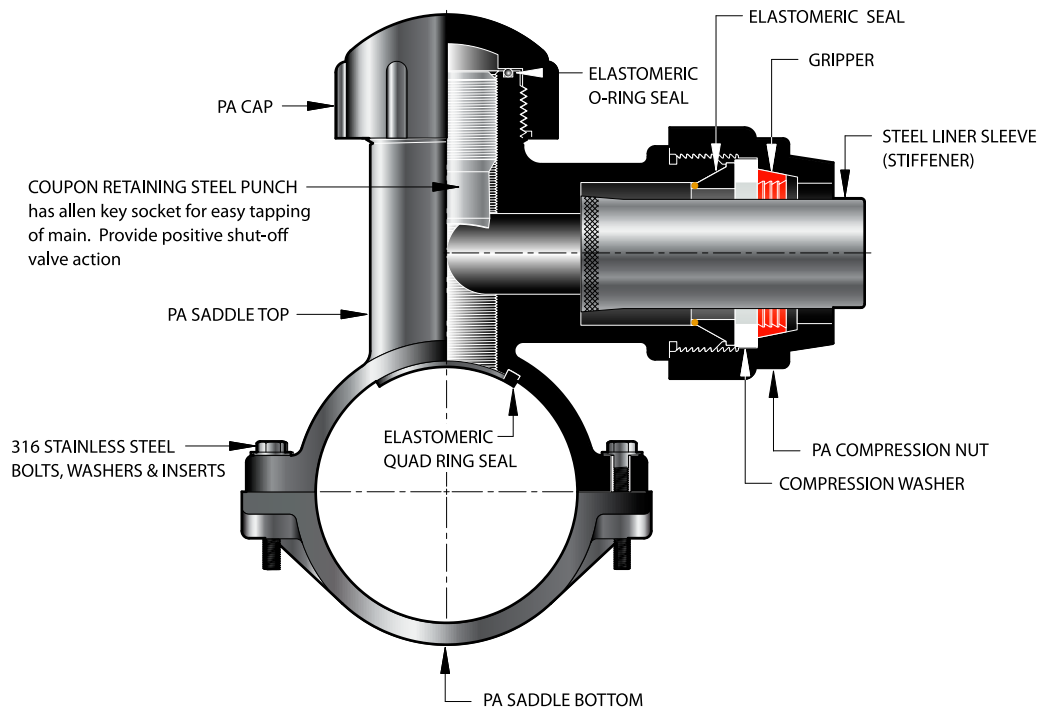

With today's labor and economic conditions, you need a better option for making 1 1/4" and 2" lateral connections to plastic pipe. Continental's PA High Volume Tee is the only mechanical saddle that offers a 1 1/2" coupon retaining punch to minimize flow restrictions and maximize gas flow. Continental's PA High Volume Tee is available for 2", 3", 4", and 6" plastic pipe. Furthermore, you can choose Con-Stab or Compression outlets for your lateral connection.

**Easy to install.** The HVT can be used on a variety of plastic fuel gas piping. Visual indicators make repeatable successful installation a cinch. The 2-stage installation is the simplest yet and the same procedure is used for 3408/4710, 2406, 2306, 3306 PE or PVC. Calibration is NOT required. And finally, the HVT easily accommodates field variable like out-of-roundness, coiled pipe, weather, and pressure testing.

**Fast.** Whereas fusion saddles require two men approximately 45 minutes to complete an installation of a single tee, installation with the HVT mechanical saddle takes just one man only 10 minutes. There's no cooling time necessary before removing clamps, before the pressure test, or before tapping the main. Auxiliary equipment like computerized controllers, generators, extension cords, clamps, scrapers, or special holding fixtures are NOT required.

**Economical.** It isn't hard to figure out that by requiring only one man 10 minutes to install the HVT, instead of the usual fusion method...the manpower savings are significant. Plus there are no long-term maintenance costs of equipment and reduced training requirements.

**Safe.** With the HVT, there's no chance of shocks from electrical equipment, no chance of burns from heater plates, and no difficulties often experienced with saddle fusions made to pressurized mains.

**Superior Dependability.** The market leader since its development in 1968. The HVT has been successfully installed millions of times...millions. The innovative design and advanced sealing methodology utilized means the extended life of the piping system. And you can count on the HVT connection to endure in the most severe environmental conditions. The superior design ensures safe operations at elevated internal pressures and the ability to exceed all requirements of ASTM F 1924.

For all your high volume lateral connections on plastic pipe, choose the super easy HVT.



# PA ELIMINATORS

## PA HVT ELIMINATORS

OUTLET (PE SIZE)	WALL	MAIN SIZE	PART NUMBER 1 1/2" CR PUNCH
1 1/4" IPS	SDR-10 (.166)	2"	5664-17-1015-00
		3"	5664-19-1015-00
		4"	5664-21-1015-00
		6"	5664-24-1015-00
	SDR-11 (.151)	2"	5664-17-1015-0A
		3"	5664-19-1015-0A
4"		5664-21-1015-0A	
2" IPS	SDR-11 (.216)	2"	5664-17-1017-00
		3"	5664-19-1017-00
		4"	5664-21-1017-00
		6"	5664-24-1017-00

- For sizes not listed, contact Continental Industries.
- PA HVT Eliminators are rated at 125 psig.
- Recommended accessories;
  - 33-4363-00 ~ 1/2" Square Drive Key, Bushing and Socket Adapter (pg 31)
  - 33-6290-00 ~ Test Plug Cap for Eliminator Saddles (pg 31)
- For Protective Sleeves, see page 32.



33-4363-00  
1/2" Square Drive Key, Bushing and Socket Adapter (pg 31)

- AVAILABLE WITH:
  - 2" to 6" IPS mains
  - Compression or Stab outlet
  - 1 1/2" coupon retaining punch
- INCREASED PRESSURE CAPABILITY:
  - All saddles are pressure rated @ 125 psi
  - PA saddles elevated temperature code CE
- POLYAMIDE MATERIAL (PA):
  - Used for 30 years in gas industry
  - Listed material in ASTM D 2513
  - Superior chemical resistance
  - PA is stronger than PE
  - Elevated temperature performance
- FULL CIRCUMFERENTIAL COMPRESSION
  - Stable foundation
  - Rotation resistance
  - Equal stress distribution
  - Simple tapping procedure

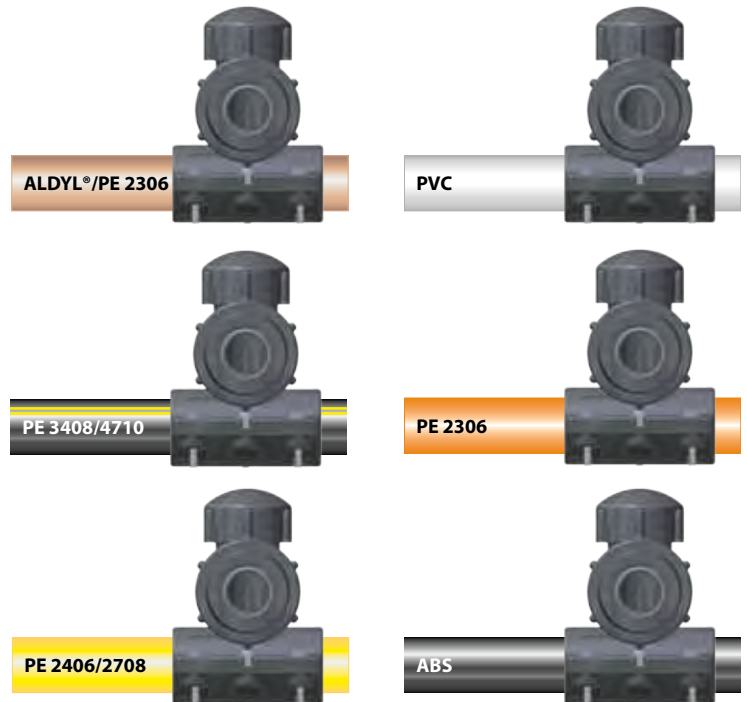

The HVT can be used on a variety of plastic fuel gas piping.



# ANODELESS METER RISERS



## ANODELESS METER RISERS

### ADVANTAGES

- Adapter machined from solid bar stock; not welded.
- Casing is TIG welded to adapter which provides a stronger and higher quality weld joint.
- Casing wall thickness exceeds ASTM requirements.
- Every part is helium leak tested.
- Bending performed through roll bending as opposed to rotary bending.
- Listed with IAPMO/UPC and CSA.

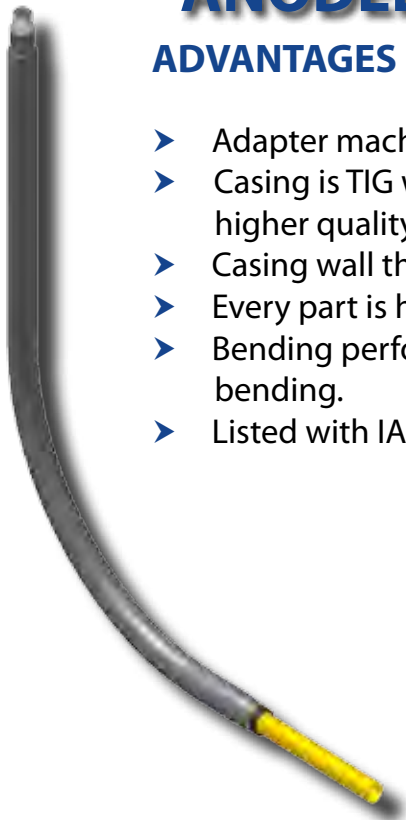

### Specifications:

- Meets or exceeds all requirements for the Categorization of Mechanical Fittings within ASTM D2513-90c Category 1, and requirements from the Code of Federal Regulations, Title 49 part 192.281, 192.283 and 192.375.
- Meets or exceeds NFPA-58.
- Listed with IAPMO/UPC and CSA.
- Pipe Threads conform to ANSI B1.20.1.
- All Gas Carrying Steel parts meet or exceed ASTM A53.
- Casing Materials meet or exceed ASTM A 513.
- All polyethylene pipe and tubing components conform to ASTM D 2513.

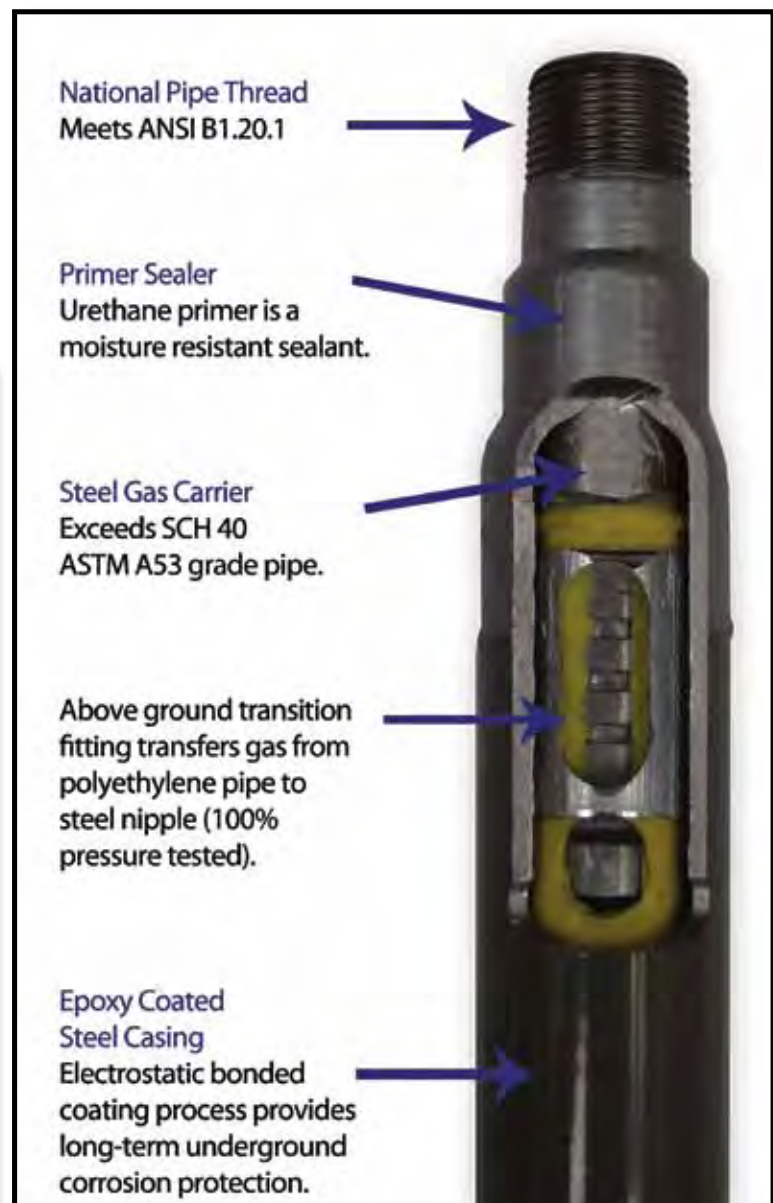





# ANODELESS METER RISERS

## ANODELESS METER RISERS

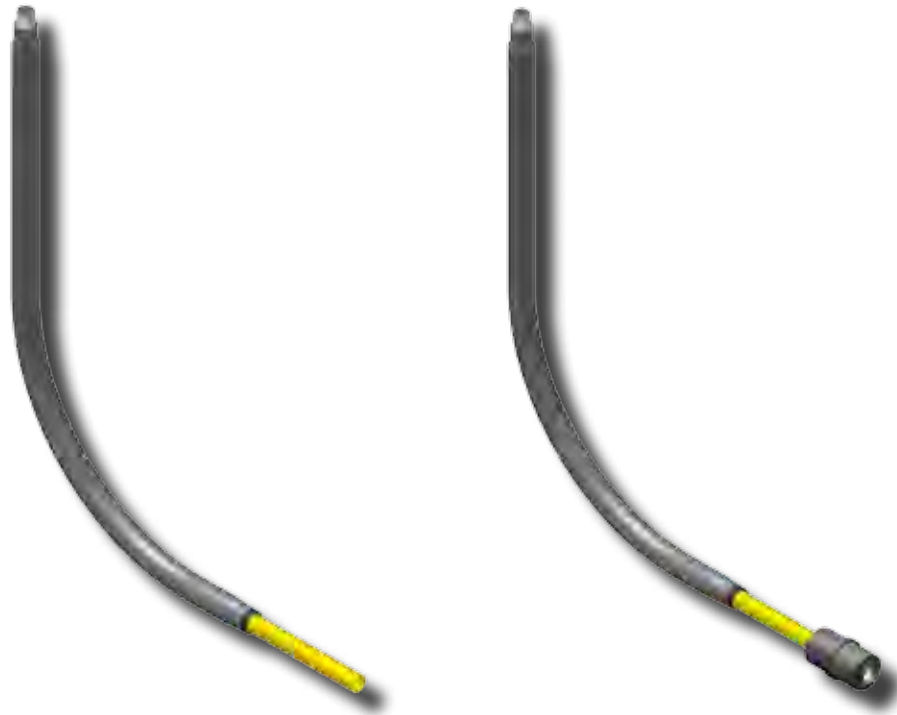

SIZE (MPT X PE)	WALL	VERTICAL LENGTH	HORIZONTAL LENGTH	PART NUMBER	PART NUMBER with Con-Stab
1/2" MPT X 1/2" CTS (5/8" OD) PE	.090	30"	15"	1253-91-4604-00†‡	1253-91-4604-25†‡
3/4" MPT X 1/2" CTS (5/8" OD) PE	.090	18"	19"	1355-91-4604-00†‡	1355-91-4604-25†‡
3/4" MPT X 1/2" CTS (5/8" OD) PE	.090	30"	17"	1353-91-4604-00†‡	1353-91-4604-25†‡
3/4" MPT X 1/2" IPS PE	SDR-9.3 (.090)	30"	17"	1353-91-4612-00‡	1353-91-4612-25
3/4" MPT X 3/4" IPS PE	SDR-11 (.095)	30"	16"	1353-91-4613-00†‡	1353-91-4613-25†‡
3/4" MPT X 1" CTS (1 1/8" OD) PE	.099/.101	30"	16"	1353-91-4608-00†‡	1353-91-4608-25‡
1" MPT X 1" IPS PE	SDR-11 (.119)	30"	16"	1453-91-4614-00†‡	1453-91-4614-25†‡
1 1/4" MPT X 1 1/4" IPS PE	SDR-10 (.166)	30"	22"	1553-91-4615-00†‡	1553-91-4615-25†
1 1/4" MPT X 1 1/4" IPS PE	SDR-11 (.151)	30"	22"	1553-91-4615-0A†‡	9953-99-0503-25†
1 1/2" MPT X 1 1/2" IPS PE	SDR-11 (.173)	36"	26"	1652-91-4616-00†‡	1652-91-4616-25‡
2" MPT X 2" IPS PE	SDR-11 (.216)	36"	30"	1752-91-4617-00†‡	1752-91-4617-25†

- **For sizes not listed, contact Continental Industries.**
- Recommended accessories for Anodeless Meter Risers with Con-Stab ID Seal® Couplings;
  - Continental's Bladed Chamfering Tool. See page 31 for size combinations available.
- Part numbers listed are for 2406 medium density polyethylene pipe. For part numbers with 3408 high density pipe, contact Continental Industries.
- † = CSA Approved / ‡ = IAPMO/UPC Listed

# CONFLEX RISERS



## CONFLEX RISERS

- ▶ ConFlex Risers are rated for 125 psig.
- ▶ ConFlex Risers conform to trench depth and flex with ground movement.
- ▶ ConFlex Risers may be installed with or without meter set present.
- ▶ ConFlex Risers have a swivel feature to allow tightening the Service Head Adapter without turning the flex hose.
- ▶ Service Head Adapter design has been used in the natural gas industry since 1967.
  - ▶ The Service Head Adapter offers a simple and dependable installation method.
  - ▶ The stiffener is integral to the adapter coupling. It does not fall out. No loose components.
  - ▶ The Service Head Adapter design is listed by IAPMO and CSA.
  - ▶ Service Head Adapter meets the requirements of ASTM F 1948 and ASTM D 2513.
- ▶ ConFlex Risers meet the requirements of;
  - ▶ ASTM D 2513
  - ▶ D.O.T. Title 49 of the Code of Federal Regulations, Part 192.283 (b) and 192.375.
  - ▶ NFPA 54 & NFPA 58
    - ▶ ConFlex Risers have a moisture seal as required in NFPA 54 & NFPA 58.
    - ▶ The Flex Hose meets 300 lb tensile requirement and 1000 lb crush requirement stated in NFPA 58.
    - ▶ The Flex Hose to Service Head Adapter joint meets 300 lb tensile requirement stated in NFPA 58.
    - ▶ Liner Sleeve provided to meet requirements of NFPA 58.
- ▶ IAPMO and CSA Listed.

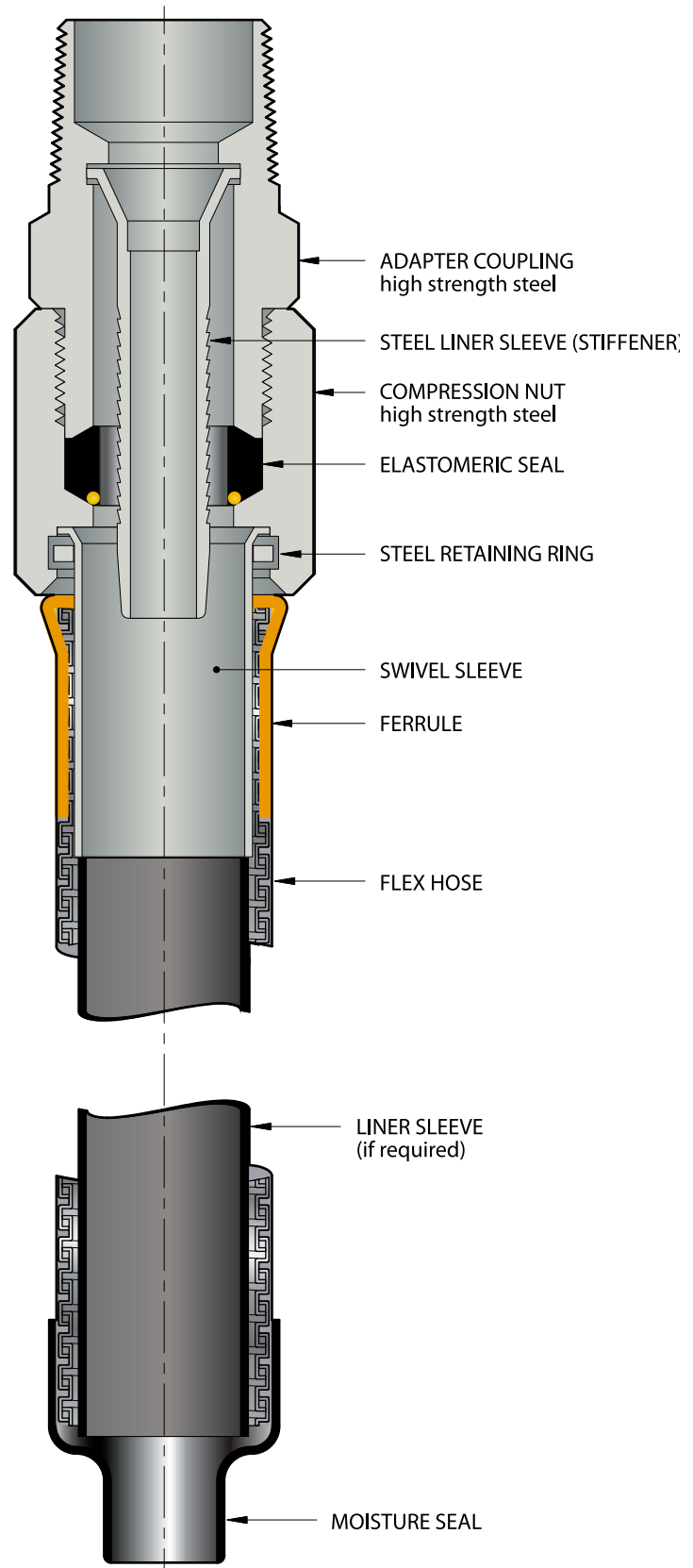



# CONFLEX RISERS

## CONFLEX RISERS

SIZE (MPT X PE)	WALL	LENGTH	PART NUMBER w/ Liner Sleeve	PART NUMBER w/o Liner Sleeve
1/2" MPT X 1/2" CTS (5/8" OD) PE	.090	36"	1253-92-1004-36†‡	1253-96-1004-36†
		60"	1253-92-1004-60†‡	1253-96-1004-60†
		72"	1253-92-1004-72†‡	1253-96-1004-72†
		84"	1253-92-1004-84†‡	1253-96-1004-84†
		96"	1253-92-1004-96†‡	1253-96-1004-96†
1/2" MPT X 1/2" IPS PE	SDR-9.3 (.090)	36"	1253-92-1012-36‡	1253-96-1012-36
		60"	1253-92-1012-60‡	1253-96-1012-60
		72"	1253-92-1012-72‡	1253-96-1012-72
		84"	1253-92-1012-84‡	1253-96-1012-84
		96"	1253-92-1012-96‡	1253-96-1012-96
3/4" MPT X 1/2" CTS (5/8" OD) PE	.090	36"	1353-92-1004-36†‡	1353-96-1004-36†
		60"	1353-92-1004-60†‡	1353-96-1004-60†
		72"	1353-92-1004-72†‡	1353-96-1004-72†
		84"	1353-92-1004-84†‡	1353-96-1004-84†
		96"	1353-92-1004-96†‡	1353-96-1004-96†
3/4" MPT X 1/2" IPS PE	SDR-9.3 (.090)	36"	1353-92-1012-36‡	1353-96-1012-36
		60"	1353-92-1012-60‡	1353-96-1012-60
		72"	1353-92-1012-72‡	1353-96-1012-72
		84"	1353-92-1012-84‡	1353-96-1012-84
		96"	1353-92-1012-96‡	1353-96-1012-96
3/4" MPT X 3/4" CTS (7/8" OD) PE	.090	36"	1353-92-1006-36	1353-96-1006-36
		60"	1353-92-1006-60	1353-96-1006-60
		72"	1353-92-1006-72	1353-96-1006-72
		84"	1353-92-1006-84	1353-96-1006-84
		96"	1353-92-1006-96	1353-96-1006-96
3/4" MPT X 3/4" IPS PE	SDR-11 (.095)	36"	1353-92-1013-36†‡	1353-96-1013-36†
		60"	1353-92-1013-60†‡	1353-96-1013-60†
		72"	1353-92-1013-72†‡	1353-96-1013-72†
		84"	1353-92-1013-84†‡	1353-96-1013-84†
		96"	1353-92-1013-96†‡	1353-96-1013-96†
3/4" MPT X 1" CTS (1 1/8" OD) PE	.099/.101	36"	1353-92-1008-36†‡	1353-96-1008-36†
		60"	1353-92-1008-60†‡	1353-96-1008-60†
		72"	1353-92-1008-72†‡	1353-96-1008-72†
		84"	1353-92-1008-84†‡	1353-96-1008-84†
		96"	1353-92-1008-96†‡	1353-96-1008-96†
1" MPT X 1/2" CTS (5/8" OD) PE	.090	36"	1453-92-1004-36†‡	1453-96-1004-36†
		60"	1453-92-1004-60†‡	1453-96-1004-60†
		72"	1453-92-1004-72†‡	1453-96-1004-72†
		84"	1453-92-1004-84†‡	1453-96-1004-84†
		96"	1453-92-1004-96†‡	1453-96-1004-96†
1" MPT X 1/2" IPS PE	SDR-9.3 (.090)	36"	1453-92-1012-36 ‡	1453-96-1012-36
		60"	1453-92-1012-60 ‡	1453-96-1012-60
		72"	1453-92-1012-72 ‡	1453-96-1012-72
		84"	1453-92-1012-84 ‡	1453-96-1012-84
		96"	1453-92-1012-96 ‡	1453-96-1012-96
1" MPT X 3/4" CTS (7/8" OD) PE	.090	36"	1453-92-1006-36	1453-96-1006-36
		60"	1453-92-1006-60	1453-96-1006-60
		72"	1453-92-1006-72	1453-96-1006-72
		84"	1453-92-1006-84	1453-96-1006-84
		96"	1453-92-1006-96	1453-96-1006-96
1" MPT X 3/4" IPS PE	SDR-11 (.095)	36"	1453-92-1013-36†‡	1453-96-1013-36†
		60"	1453-92-1013-60†‡	1453-96-1013-60†
		72"	1453-92-1013-72†‡	1453-96-1013-72†
		84"	1453-92-1013-84†‡	1453-96-1013-84†
		96"	1453-92-1013-96†‡	1453-96-1013-96†
1" MPT X 1" CTS (1 1/8" OD) PE	.099/.101	36"	1453-92-1008-36†‡	1453-96-1008-36†
		60"	1453-92-1008-60†‡	1453-96-1008-60†
		72"	1453-92-1008-72†‡	1453-96-1008-72†
		84"	1453-92-1008-84†‡	1453-96-1008-84†
		96"	1453-92-1008-96†‡	1453-96-1008-96†
1 1/4" MPT X 1" CTS (1 1/8" OD) PE	.099/.101	36"	1553-92-1008-36†‡	1553-96-1008-36†
		60"	1553-92-1008-60†‡	1553-96-1008-60†
		72"	1553-92-1008-72†‡	1553-96-1008-72†
		84"	1553-92-1008-84†‡	1553-96-1008-84†
		96"	1553-92-1008-96†‡	1553-96-1008-96†
1 1/4" MPT X 1 1/4" IPS PE	SDR-10 (.116)	36"	N/A	1553-96-1015-36†‡



• For sizes not listed, contact Continental Industries.  
 • † = CSA Approved / ‡ = IAPMO/UPC Listed

# CONFLEX RISERS



## RISER BRACKETS



17-6133-00  
6" Stand-Off

- (2) 3/8" wide x 2" long angular mounting slots
- Accommodates 1/2" thru 1 1/4" flex risers
- Powder coated finish
- Mounting hardware included



17-6134-00  
9" Stand-Off

- (2) 3/8" wide x 2" long angular mounting slots
- Accommodates 1/2" thru 1 1/4" flex risers
- Powder coated finish
- Mounting hardware included



17-6134-01  
9" Stand-Off

- Accommodates 1/2" thru 1 1/4" flex risers
- Powder coated finish
- Mounting hardware included

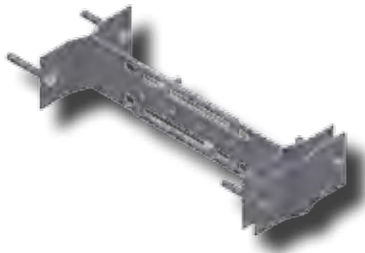

17-6135-00  
Universal Riser Bracket

- Can be used for virtually any mounting situation
- Foundation, single or double remote installations
- Accommodates 1/2" thru 2" risers
- Carriage bolts supplied for ease of assembly
- Powder coated finish
- Foundation mounting hardware included
- (2) 3/8 wide x 1-5/8 straight mounting slots  
(Drivepost shown sold separately)

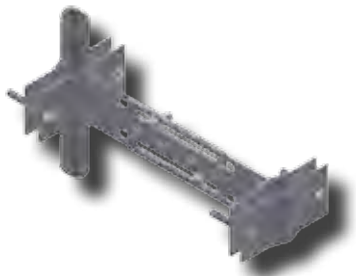



# ID CHAMFERING TOOLS

## To Be Used With Con-Stab ID Seal® Fittings

CATALOG NO.	DESCRIPTION
<b>ID CHAMFER TOOLS WITH GAUGE</b>	
0000-33-6580-04	1/2" CTS (5/8" OD) .090 WALL
0000-33-6580-02	1" CTS (1 1/8" OD) .090 WALL
0000-33-6580-11	3/4" CTS (7/8" OD) .077 WALL
0000-33-6580-06	3/4" CTS (7/8" OD) .090 WALL
0000-33-6580-08	1" CTS (1 1/8" OD) .099/.101 WALL
0000-33-6580-12	1/2" IPS SDR-9.3
0000-33-6580-13	3/4" IPS SDR-11
0000-33-6580-14	1" IPS SDR-11
0000-33-6580-03	1 1/4" CTS (1 3/8" OD) .090 WALL
0000-33-6580-10	1 1/4" IPS SDR-11 (.151 WALL)
0000-33-6580-15	1 1/4" IPS SDR-10 (.166 WALL)
0000-33-6580-09	1 1/4" IPS SDR-9.3 (.178 WALL)
0000-38-6580-16	1 1/2" IPS SDR-11
0000-33-6580-17	2" IPS SDR-11



## ACCESSORIES

### For Eliminators & HVT's



- 33-5505-00 ~ Combination Tapping Tool & Saddle Bolt "T" Wench for 1 1/4" thru 6" IPS Con-Stab ID Seal® Eliminators
- 33-5505-01 ~ Combination Tapping Tool & Saddle Bolt "T" Wench for 3" thru 8" IPS Con-Stab ID Seal® Eliminators



33-4363-00 ~ 1/2" Square Drive Key, Bushing & Socket Adapter Ass'y for HVT Eliminator Saddles



- 33-5508-00 ~ Test Plug Cap for Eliminator Saddles with 1/4" FPT for attachment of quick connect coupling
- 33-6290-00 ~ Test Plug Cap for HVT Saddles with 1/4" FPT for attachment of quick connect coupling

## ACCESSORIES



## PE PROTECTIVE SLEEVES



CATALOG NUMBER	DIAMETER		LENGTH	FOR USE WITH CONTINENTAL PRODUCTS			
	INTERNAL	OUTSIDE		STEEL FITTINGS	PVC FITTINGS	PA FITTINGS	STAB FITTINGS
44-2585-00	1.370/1.395	1.612	12"		1/4" OD & 7/8" OD P.E. Compression O/L's		
44-2586-00	1.875/1.915	2.190	12"		3/8" OD & 5/8" OD P.E. Compression O/L's	3/8" OD & 5/8" OD P.E. Compression O/L's	
44-2587-00	2.375/2.425	2.760	12"	3/8" OD, 5/8" OD P.E. Compression O/L's	1 1/8" OD, 1/2" IPS & 3/4" IPS P.E. Compression O/L's	1 1/8" OD P.E. Compression O/L's	
44-2588-00	2.375/2.425	2.760	21"	5/8" OD, 1/2" IPS & 3/4" IPS P.E. Transition O/L's			
44-2589-00	2.875	3.270	24"	7/8" OD, 1/2" IPS P.E. Compression O/L's	1" IPS P.E. Compression O/L's	3/4" IPS & 1" IPS P.E. Compression O/L's	5/8" OD, 7/8" OD, 1 1/8" OD, 1/2" IPS, 3/4" IPS & 1" IPS O/L's
				1 1/8" OD, 1" IPS P.E. Transition O/L's			
44-5753-00	4.250 MIN.	4.760	24"	1 1/8" OD, 3/4" IPS, 1" IPS, 1 1/4" IPS & 1 1/2" IPS P.E. Compression O/L's	1 1/4" IPS P.E. Compression O/L's	1 1/4" IPS P.E. Compression O/L's	1 1/4" IPS & 1 1/2" IPS O/L's
				1 1/4" IPS P.E. Transition O/L's			
44-5754-00	5.200 MIN.	5.820	36"		2" IPS P.E. Compression O/L's	2" IPS P.E. Compression O/L's	2" IPS O/L's

**NOTE:** It is advisable to limit shear at main connections. In this regard, your company's policies should be followed. For further information, reference; ASTM D 2774 Standard Practice for Underground Installation of Thermoplastic Pressure Piping; Code of Federal Regulations, Title 49, Transportation Part 192; AGA Plastic Pipe Manual and/or The Guidance Manual for Operators of Small Gas Systems by the U.S. Department of Transportation.

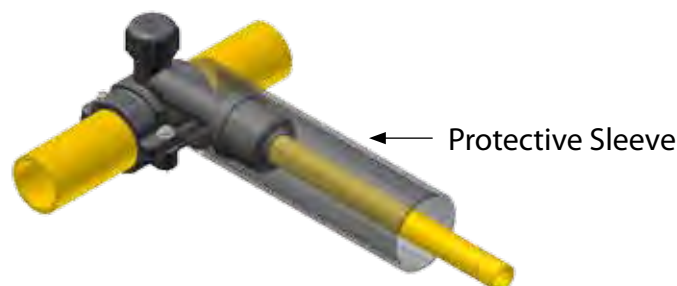





# ASSEMBLY INSTRUCTIONS : I.D. SEAL® CON-STAB

**IMPORTANT**

**For use on:**  
Polyethylene gas pipe meeting the requirements of ASTM D 2513

**Pressure Rating:** 125 psig MAOP

**Operating Temperature:** -20 to 140° F

**1** Verify the stab fitting is the correct size for the polyethylene (P.E.) pipe. Verify the SDR (or wall thickness) of the pipe matches the SDR (or wall thickness) printed on the fitting label.



**2** Cut pipe ends square.



**3** Clean piping thoroughly to assure there is no dirt, grease or oil in assembly area.



**4a** Chamfer end of pipe using [Continental's ID chamfering tool with ID gauge](#).

or



**4b** Chamfer end of pipe using [Continental's double ended ID chamfering tool](#).



**5** Mark the stab depth by inserting pipe into ID chamfer tool and marking the pipe at the entrance as shown.



**6** If using ID chamfer tool with gauge, check for proper chamfer by inserting pipe on gauge up to the o ring. With proper chamfer, o ring will begin to enter pipe.



**7** Stab pipe completely into fitting entrance.



**8** Stab pipe completely into fitting so that the mark on the pipe is within 1/8" from the fitting entrance.



**9** Repeat steps 1 thru 8 for all Con-Stab joints.

**10** To assure proper assembly and to comply with 49 CFR 192 Subpart J—Test Requirements, the joint shall be leak tested.



PATENT #'S 5,366,260, 5,692,785 & 5,853,272

# OTHER AVAILABLE PRODUCTS



## GEO-STAB® - THE FASTEST WAY TO INSTALL HEAT PUMP LOOPS WITHOUT FAIL

The GEO-Stab® fitting provides a reliable, productive, and efficient approach to loop installation for the geothermal heat pump industry. The GEO-Stab® fitting system incorporates an advanced and proven fusionless technology, fully engineered for geothermal heat pump applications. This system is designed to greatly reduce installation time at the job site and the GEO-Stab® fitting joints are designed to be stronger than the pipe itself!

### A NEW SYSTEM FOR A PROVEN APPLICATION

The GEO-Stab® fitting features an INTERNAL SEAL and is an all plastic fitting that contains no metal parts.

### THE GEO-Stab® IS A COST EFFECTIVE JOINING METHOD

There is no additional assemble equipment required for installation - just chamfer the polyethylene pipe and stab. That's all there is to it! The GEO-Stab's uni-body design eliminates all external parts. The result is a continuous external HDPE body construction that provides for continuity of material throughout the ground loop system. This simplistic design has been pressure rated to 160 psi and results in a joint that is stronger than the pipe itself.

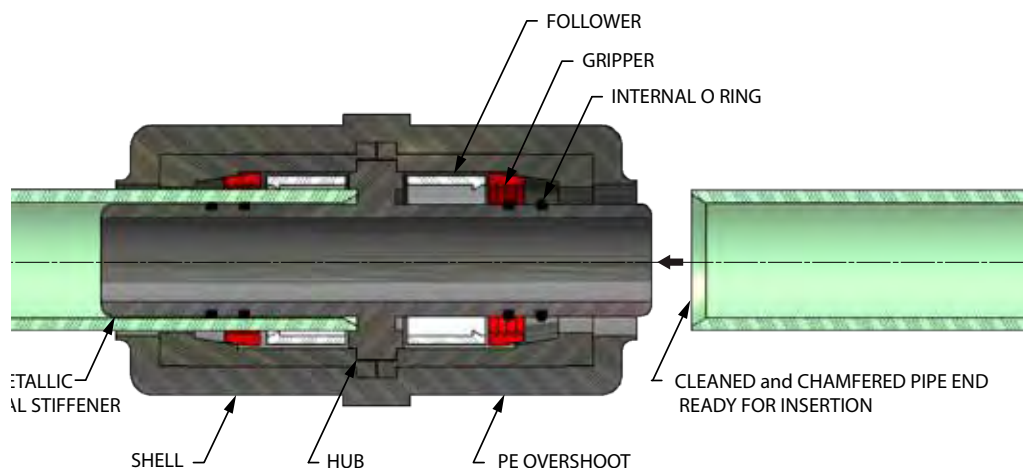



# OTHER AVAILABLE PRODUCTS

## CONTINENTAL'S PVC WATER SADDLES

FACTS • FEATURES • BENEFITS

### FASTTAP



- Full wrap around saddle design eliminates stress points being applied to main.
- Tapping process uses simple combination tapping tool eliminating cumbersome tapping machines.
- Tapping cutter retains the coupon then functions as a cut-off valve eliminating corporation stops.
- Manufactured from non-corrosive materials.
  - PVC with PPI HDB Listing
  - 316 Stainless Steel Bolts
  - Brass Cutter
- Available to work with 4"-10" AWWA C-900 and 1 1/4"-12" iron pipe size mains.
- Compression, solvent-weld and threaded outlets for 3/4" to 1" PVC, PE, PB and copper tubing.
- Application may be for wet or dry taps.
- See [www.nsf.org](http://www.nsf.org) for Continental's NSF Listing to Standard 61.
- Reduces time involved with installation by 50%!

### FASTTHRED



- PVC saddles for IPS mains.
- Excellent for dry taps and irrigation systems.
- Available in 1 1/4" thru 8" iron pipe size mains.
- Compression, solvent-weld and threaded outlets for 3/4" to 1" PVC, PE, PB and copper tubing.



### SUPER FASTTAP



- Full wrap around saddle design eliminates stress points being applied to main.
- Tapping process uses simple combination tapping tool eliminating cumbersome tapping machines.
- Tapping cutter retains the coupon then functions as a cut-off valve eliminating corporation stops.
- Manufactured from non-corrosive materials.
  - PVC with PPI HDB Listing
  - 316 Stainless Steel Bolts
- Available to work with 2"-6" iron pipe size mains.
- Compression and solvent-weld outlets to work with 1 1/4" and 2" PVC, PE, PB tubing.
- Application may be for wet or dry taps.
- See [www.nsf.org](http://www.nsf.org) for Continental's NSF Listing to Standard 61.
- Reduces time involved with installation by 50%!

**Fasttap® Saddles are your Saddle, Tapping Machine and Corporation Stop, All in One Dependable and Economical Unit.**

# OTHER QUALITY PRODUCTS FROM CONTINENTAL INDUSTRIES

GAS DISTRIBUTION PRODUCTS  
**PA MECHANICAL  
SADDLES & FITTINGS**



PA Mechanical  
Saddles & Fittings

GAS DISTRIBUTION PRODUCTS  
**METER RISERS**



Meter Risers

GAS DISTRIBUTION PRODUCTS  
**IN-LINE REPAIR  
FITTINGS**



FROM STANDARD TO SPECIALS,  
CONTINENTAL INDUSTRIES HAS YOUR IN-LINE REPAIR FITTING.  
NO OTHER SINGLE MANUFACTURER CAN OFFER THE VARIETY  
OF REPAIR FITTINGS THAT  
CONTINENTAL INDUSTRIES PROVIDES.



In-Line Repair Fittings

GAS DISTRIBUTION PRODUCTS  
**STEEL SERVICE TEES**



Steel Service Tees

GAS DISTRIBUTION PRODUCTS  
**TRANSITION FITTINGS**

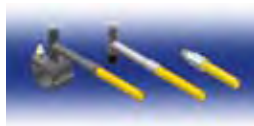

Transition Fittings

WATER DISTRIBUTION PRODUCTS  
**PVC WATER FITTINGS**



PVC Water Fittings

GAS DISTRIBUTION PRODUCTS  
**STEEL  
COUPLINGS**



Steel Couplings

GAS DISTRIBUTION PRODUCTS  
**EFV FITTING  
CATALOG**



EFV Catalog

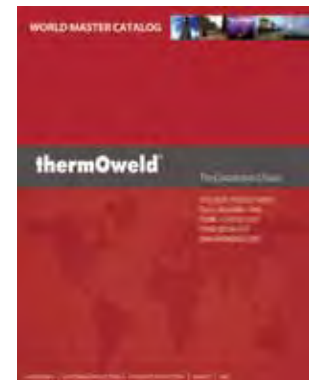

thermOweld® for  
Cathodic Protection



## Continental Industries

1140 North 129th East Ave. Tulsa, Oklahoma 74116

(Phone) 800-558-1373 or 918-627-5210

(Fax) 800-788-1668 or 918-622-1275

[www.conind.com](http://www.conind.com)

The Ultimate Connection