

ELECTROFUSION FITTINGS

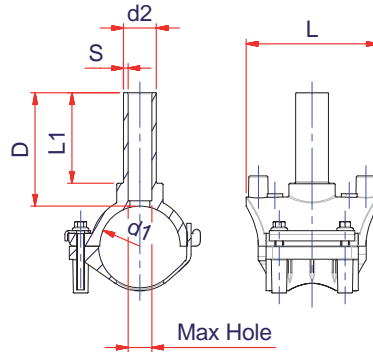

BRANCH SADDLE WITH RIGID UNDER CLAMP

PE4710 230 PSI

Code	Nominal Size	Max SDR	pcs/box	Q.ty pallet	Weight kg./p.	Volume m ³ /p.	d1	d2	S	L1	L	D	Max Hole
12EICOL11412C	1-1/4" x 1/2" CTS	-	60	720	-	0.0013	1-1/4"	1/2" CTS	0.10	2.56	3.94	3.27	0.36
12EICOL0212C	2" x 1/2" CTS	-	50	600	0.294	0.0016	2"	1/2" CTS	0.10	2.56	3.94	3.27	0.36
12EICOL11434	1-1/4" x 3/4" IPS	-	60	720	-	0.0013	1-1/4"	3/4" IPS	0.09	2.56	3.94	3.27	0.77
12EICOL0234	2" x 3/4" IPS	-	50	600	0.296	0.0016	2"	3/4" IPS	0.09	2.56	3.94	3.27	0.77
12EICOL11401C	1-1/4" x 1" CTS	-	60	720	-	0.0013	1-1/4"	1" CTS	0.10	2.56	3.94	3.27	0.86
12EICOL0201C	2" x 1" CTS	-	50	360	0.299	0.0016	2"	1" CTS	0.10	2.56	3.94	3.27	0.86
12EICOL11401	1-1/4" x 1" IPS	-	60	720	-	0.0013	1-1/4"	1" IPS	0.12	2.56	3.94	3.27	1.02
12EICOL0201	2" x 1" IPS	-	50	600	0.301	0.0016	2"	1" IPS	0.12	2.56	3.94	3.27	1.02
12EICOL0202	2" x 2" IPS	-	30	360	0.333	0.0026	2"	1" IPS	0.23	3.54	5.20	4.72	1.55

Fittings may be fused on pipe with SDR'S 7.0 to 17.0